

ELECTRONIC JOURNALISM II

**PUBLIC AFFAIRS**

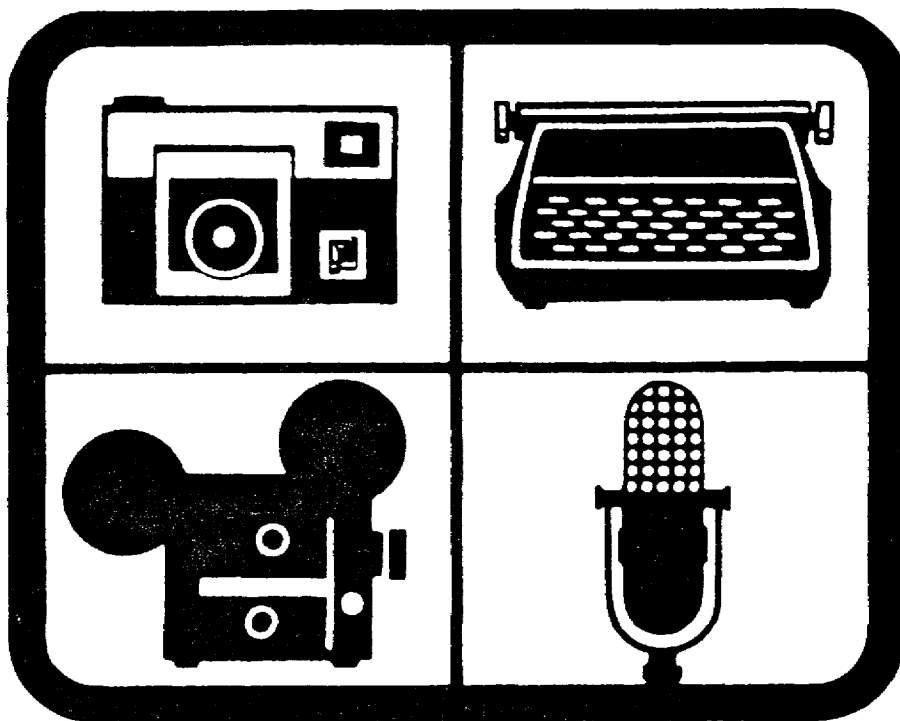

THE ARMY INSTITUTE FOR PROFESSIONAL DEVELOPMENT  
ARMY CORRESPONDENCE COURSE PROGRAM

**A  
I  
P  
D**

READINESS/  
PROFESSIONALISM



THRU  
GROWTH

# ELECTRONIC JOURNALISM II

## Subcourse Number DI 0351

### EDITION A

Army Public Affairs Center  
Fort George G. Meade, Maryland

10 Credit hours

Edition Date: September 1990

### SUBCOURSE OVERVIEW

We designed this subcourse to provide you with an entry-level understanding of the operation of Electronic News Gathering (ENG) and Electronic Field Production (EFP) equipment; the selection and set up of microphones; the preparation and performance of TV news inserts; videotape editing; and the responsibilities and functions of an ENG Team Chief. This subcourse is presented in five lessons. You must have a basic knowledge of military broadcasting prior to taking this subcourse. There are no prerequisites to this subcourse. However, it is suggested you complete Subcourse DI0350, Electronic Journalism I, before taking this subcourse.

This subcourse reflects the doctrine current at the time the subcourse was prepared. In your own work situation, always refer to the latest official publications.

Unless otherwise stated, the masculine gender of singular pronouns is used to refer to both men and women.

### TERMINAL LEARNING OBJECTIVE

**ACTION:** You will learn about the operation of ENG/EFP equipment; the selection and set up of microphones; the preparation and performance of TV news inserts; how to edit videotape; and how to perform as an ENG Team Chief.

**CONDITION:** You are given the material presented in this lesson.

**STANDARD:** To demonstrate competency of this task, you must achieve a minimum of 75 percent on the subcourse examination.

TABLE OF CONTENTS

	Page
Subcourse Overview .....	i
Lesson 1: Operate ENG Equipment .....	1
Practice Exercise .....	17
Answer Key and Feedback .....	18
Lesson 2: Select and Set Up Microphones .....	19
Practice Exercise .....	33
Answer Key and Feedback .....	34
Lesson 3: Prepare/Perform TV News Inserts .....	35
Practice Exercise .....	73
Answer Key and Feedback .....	74
Lesson 4: Edit Videotape .....	75
Practice Exercise .....	83
Answer Key and Feedback .....	84
Lesson 5: Perform as ENG Team Chief .....	85
Practice Exercise .....	97
Answer Key and Feedback .....	98

## LESSON ONE

### OPERATE ENG EQUIPMENT

46R Soldier's Manual Task: 214-177-1315

#### OVERVIEW

#### LESSON DESCRIPTION:

This lesson will provide you an overview of the operation of ENG/EFP equipment.

#### LEARNING OBJECTIVE:

**ACTION:** Describe procedures necessary to properly obtain, in a field environment, video and audio for television production.

**CONDITION:** You are given the material presented in this lesson.

**STANDARD:** Perform all the duties described in this lesson.

**REFERENCES:** The material contained in this lesson was derived from the following publications:

STP 46-46R14-SM-TG Soldier's Manual & Trainer's Guide,  
Broadcast Journalist, MOS 46R Skill Levels 1/2/3/4, August  
1988.  
Defense Information School Radio and Television Handbook, May  
1982.

## **OPERATE ENG EQUIPMENT**

### **INTRODUCTION**

The age of the high-quality, portable mini-camera is here and here to stay (See Lesson One, Subcourse DI0350). The advent of small-format video systems truly revolutionized the television industry, particularly Army broadcasting. Where once we could only use a film camera, the Electronic News Gathering/Electronic Field Production camera has effectively replaced this older system with cost-effective, portable news gathering equipment. Not only is it portable, it can even allow the broadcaster to play back the recording on the spot. With the older film format, the process was not only time-consuming to develop and see the film, but also expensive by comparison.

Where Lesson One of Subcourse DI0350 discussed equipment common in today's ENG/EFP systems, this lesson will deal with the operation of that equipment. With advancements in technology so rapid they often make new equipment obsolete even before it hits the market, it is difficult to keep reference and learning materials up to date. Therefore, this lesson will concentrate on the type of equipment issued to United States Army Reserve Component, since that equipment is standard for more than 60 public affairs units.

Since the basic operation of equipment differs little between ENG and EFP, this lesson will address ENG with notations wherever there would be a significant difference for EFP. The primary difference between ENG and EFP is evident in the terminology. ENG is the coverage of uncontrolled events such as training accidents and fires. The pictures and story are gathered on the scene, as the events happen. EFP uses the same equipment, but under controlled circumstances. A story or script is usually written in advance. The event is carefully planned and executed until the final product is finished with predetermined results. The production of television spots, sporting events and planned events that take place outside the television studio are examples of Electronic Field Productions.

### **THE CAMERA**

For anything to be seen by anyone on a television screen, it had to be previewed by a television camera before the introduction of digital electronics. The images that appeared were determined by what a camera could see and how it could see them. Therefore, the most obvious production element in television was always the camera. All other elements and techniques were geared to the physical and electronic

characteristics of the camera. Lighting, scenery, audio, writing, and directing all depended on the potential of the camera.

Where once they were large and bulky, cameras have evolved to smaller, lighter, more easily handled pieces of equipment. Portability, along with the advent of videotape, even allowed the television camera to replace the film camera in the gathering of news. In ENG/EFP where actual events are the topic, we are concerned mostly with portable cameras.

It is the intent and design of these portable cameras to be quickly and easily adjustable to extreme production situations. (See Fig. 1-1 Basic camera.)

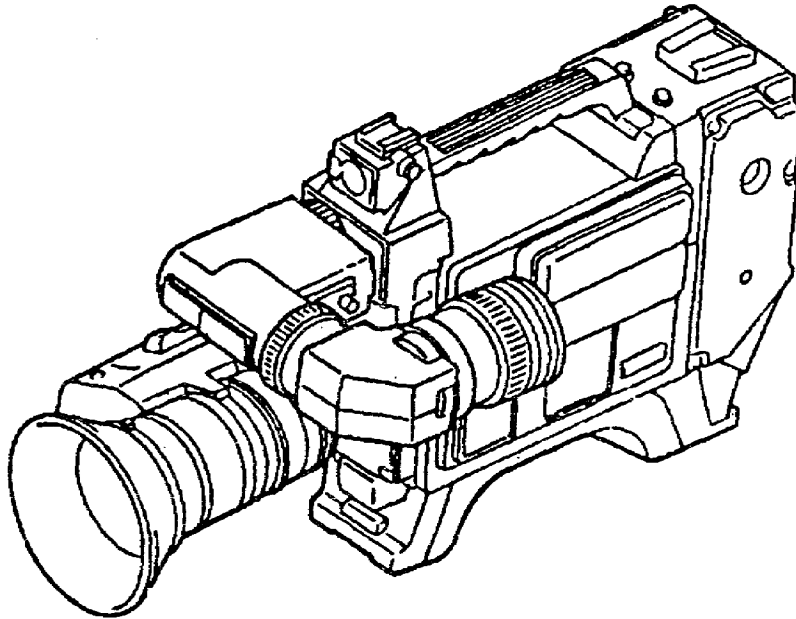

FIGURE 1-1. BASIC CAMERA

There are three major parts to the television camera. They are the lens, body and viewfinder. Since they were discussed in lesson one of subcourse DI0350, this lesson will be more concerned with the effect of each on camera operation.

### **CAMERA BODY**

The camera body consists of the housing and those parts inside it. That includes either camera pickup tube(s) or a solid state image device and the internal optical system.

The internal optical system is a series of prisms or mirrors. There are also circuitry boards, resistors, capacitors and wires. This assortment of electronics takes the visual information it receives from the internal optical system, processes it, and converts it into electronic impulses for feed to another source.

The other source can be a monitor, a videotape recorder or a system to put it directly on the air. Cameras have video out connectors through which the electronic information passes. (See Fig. 1-2 Camera Output Connector.)

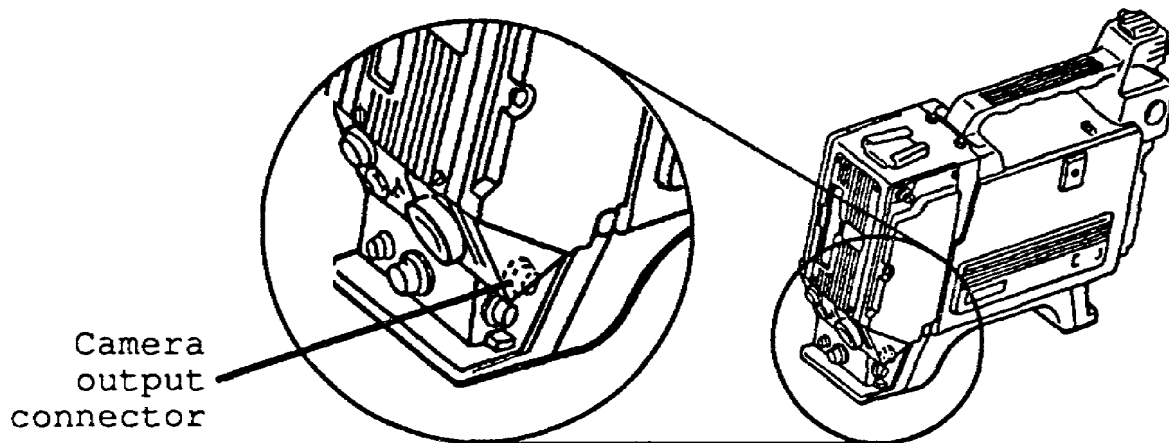

FIGURE 1-2. CAMERA OUTPUT CONNECTOR

At the front of the camera body is the Color Temperature Compensation Filter Disc, more simply referred to as the filter wheel (See Fig. 1-3 Filter disc). This enables rapid adjustment to varying light conditions with just the turn of a wheel. There are three or four positions. They are: 3200 degrees Kelvin; 5600 degrees Kelvin; 5600 +1/8 ND (Neutral Density) or +1/4 ND (see Lesson Two, Lighting for ENG, subcourse DI0350). Some cameras -not all -have a fourth position, which is a cap. The filter wheel must be set in the proper position before you white balance the camera (3200 degrees Kelvin for artificial lighting, 5600 for daylight, and +1/8 or 1/4 ND for bright sunlight). The filters will aid in the white balance process. As you learned in Lesson Two, Lighting for ENG, Subcourse DI0350, white balancing is the procedure that insures the camera can reproduce colors accurately.

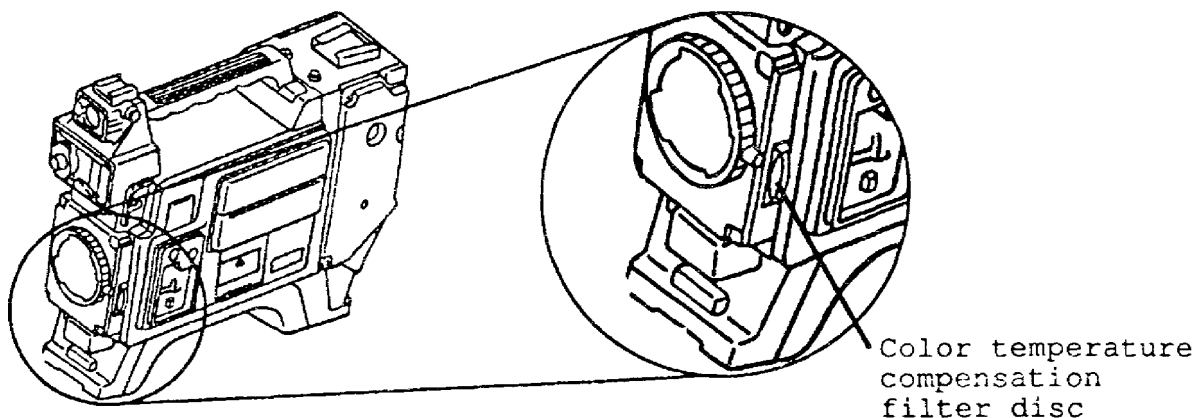

FIGURE 1-3. FILTER DISC

## **THE LENS**

As you learned in Subcourse DI0350, the lens and certain attachments to it are sometimes called the external optical system. The lens selects a certain field of view and produces a small, clear optical image of this view.

With the lens we have four primary concerns. These are: focal length, focus, f-stop and depth of field. What you need to do now is understand the functions of each, and apply them to your use as an ENG videographer.

If some things are repeated in this lesson, it is merely to save you the effort of having to go back and refer to subcourse DI0350.

### **Focal Length**

Portable television cameras, the cameras we're concerned with, have a zoom, or variable focal-length lens, which enables them to select fields of view at different distances from the camera without moving the camera. It allows you to change the focal length of the lens from long to short and from short to long in one continuous operation.

There is an important difference between zooming in or out, and physically repositioning the camera closer or farther away. (A camera movement called "dolly in" or "dolly out." See Fig. 1-5.) The wide use of a zoom lens and its ease of operation has caused many videographers and directors to rely on the zoom when they should move the camera. A zoom lens simply magnifies or reduces an image, but it's necessary to dolly the camera to get the full three-dimensional effect. This is particularly important when moving past doorways, arches or stationary objects.

The degree to which you can change the focal length of a zoom lens is called the zoom range. To you, the operator, it's more important to know the magnification, rather than the numbers. That is something that will come only with experience. Some cameras have a "times two function," which allows you to double the focal length at any point in the zoom. That is another area where you'll need experience in order to become proficient. By recording the change from "times one" to "times two," or the other way around, you can create an interesting effect, if you do it properly.

The speed at which the focal length of a zoom lens can be changed is determined by the operator, whether it is done manually or with a zoom servo.



A zoom servo is nothing more than a small motor controlled by a lever. How far the lever is depressed determines the speed of the zoom. There are situations where a slow zoom would be better than a fast one, and other times when the fast zoom would be preferred. You'll have to develop a touch to be able to control the speed as well as a feel for the speed required in each case.

The various focal lengths of lenses have varying effects on your video. Things to consider are: field of view, perspective, distortion, depth of field, effect of camera movement and subject movement, and limitations you'll have to deal with. Subcourse DI0350 discusses these at length. Once you learn them, it will be much easier to understand how they will affect your video product. Be sure to use them to your advantage.

### **Focus**

Focus with a lens is the same thing as focus with the eye. Sharp and clear is in focus, while fuzzy and unclear is out of focus.

Whenever possible, you should zoom focus. That means to zoom all the way in, focus and zoom back out to the desired shot. Not only does it keep more of the videospace in focus when you zoom back out, but when zoomed-in everything is magnified and you'll be able to see much finer details to focus on. That means your focus will be much clearer and sharper. Rack focus means to focus the shot where it is and, unless a certain effect is desired, is done whenever situation or time don't permit a zoom focus.

### **f-Stop**

Since too little light falling on the pick-up tube or chip will make the picture quality suffer, it is extremely important to be sure you have enough light. Since the camera will be used both indoors and outdoors, you will have to adjust for extreme variations in light levels. You probably won't be carrying a light meter, so you'll need some way to know whenever the light level is sufficient.

Your camera has both automatic and manual iris controls (See Subcourse DI0350). Most of the time, you'll want to use the automatic control. Changing focal lengths requires a change of lens diaphragm opening and this can be accomplished more efficiently by the automatic control. It can even inform you if there is insufficient light. If the automatic iris is all the way open, the camera is seeking more light. If you move the dB gain switch to 9dB and the automatic iris doesn't close down at all, you still don't have enough light to operate the camera. It has to be very

dark to require using the 18dB gain, and picture quality suffers greatly, so use the 18dB gain only in cases of absolute emergency. EXAMPLE: A video crew at the November 1989 destruction of the Berlin wall with daylight fading and no lights on hand would have used the 18dB gain because a substandard picture is better than no picture at all.

Keep in mind, the automatic iris control will do everything for you, but it deals with the average light level for the video space. That means, if you're shooting video of someone standing in the middle of a field covered in snow, he will appear as a dark silhouette because the automatic iris will give you the opening required by most of the picture, which is the snow. As long as you are aware of this fact, you can go to manual control whenever necessary. Because of the contrast range limitations of the camera, you will come across conditions where the camera won't be able to encompass everything the eye can see. It's up to you, the operator, to know the limitations so that you can make sure that what is lost is not essential to the shot.

*f*-stops affect more than just the amount of light entering the camera and this is important for the ENG operator to know. They also affect the depth of field.

### **Depth of Field**

As you know, the depth of field is that area of the field of view where the objects are in focus. You know too, that you can control the depth of field with: lens diaphragm opening, camera to subject distance and focal length of the lens. You will want to exercise that control for different purposes. You may want a shallow depth of field in order to separate your subject from the background or foreground. You may want a greater depth of field so you can move around without getting your subject out of focus too easily. The important thing is for you, the operator, to understand the basic principles and apply them properly.

### **THE VIEWFINDER**

The viewfinder shows you what the camera sees. (See Fig. 1-4.) Since it is a miniature television, it has brightness and contrast controls. This can fool you when it comes to satisfactory light levels. What appears to be enough light in the viewfinder may not be, because the brightness control is turned up. Never rely on the brightness of the picture in the viewfinder to indicate light levels.

Use the viewfinder to frame, compose and focus the camera shots. In addition, there are a number of functions commonly displayed in the

viewfinder eyepiece. These can include any or all of the following:

- o A recording light to indicate the recorder is on or off.
- o Battery warning lights to indicate low levels in both the camera and recorder batteries.
- o A tape warning light to indicate the recording tape is nearing the end.
- o A camera db gain indicator.
- o A low light-level indicator.

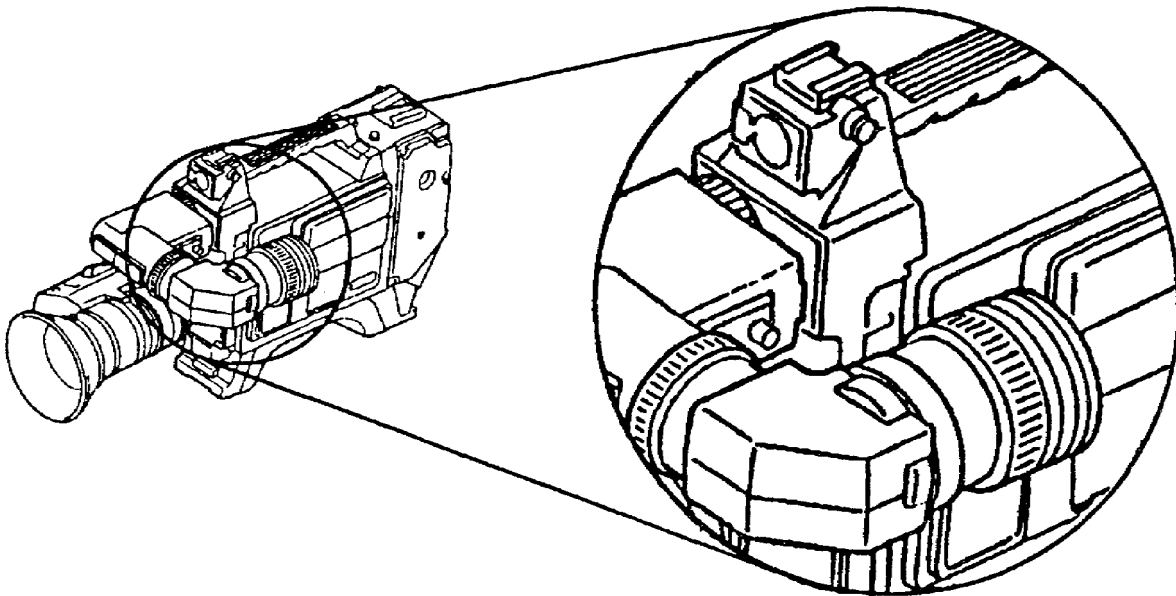

FIGURE 1-4. VIEWFINDER

### **CAMERA OPERATION**

In ENG there are a number of things you need to master, not the least of which is camera operation. Before you can operate the camera, or any other equipment, you must accomplish setup. Usually the camera and the recorder are set up at the same time. Set them up by inserting a battery or connecting an AC adaptor. When you have connected the camera and recorder with a video cable, turn the power on and check the battery charge with the camera battery level indicator. Check the videocassette for the needed red pin and insert the cassette into the recorder.

Connect the hand-held microphone (see Lesson Two, Select and Set Up Microphones) to the recorder. Connect the headphones to the recorder. Set up the needed lights (see Lesson Two, Lighting for ENG, Subcourse

DI0350), or reflectors if natural light is used. Set up the tripod.

Of course, you must learn the technical aspects. You will need to be able to white balance the camera according to the operator's manual. Likewise, you'll have to be able to record with it, but just as important, you'll need to perfect the aesthetics. You won't always have a script available to you beforehand, especially in the coverage of fast-breaking spot news. When you do have a script available prior to shooting, it's a good habit to recheck it for any additional video requirements.

### **Camera Commands**

Television production has a language of its own, and it's important that you learn it. As we go over the different camera movements, we'll call them by name. Each name, or movement, should be referred to by that term. Everyone in the industry knows the language and can communicate effectively on a common level. EXAMPLE: It may seem nitpicky, but when talking about shooting with a portable television camera you should use the term videotape rather than "filming." After all, film is an entirely different medium and although most people who misuse the term know what they mean, it takes away all chance of misunderstanding to say what you mean.

### **Camera movement**

There are two ways to move a camera: Changing the aim of the camera, and changing the position of the camera. EXAMPLE: As a subject moves from left to right across your field of view, you can "follow" it by changing the aim from left to right in order to keep it in your picture. You can also "follow" it by moving the camera from left to right at the same rate without changing the aim at all. That's why we use specific movement language instead of just saying, "follow it."

**Pan.** Horizontally pivoting the camera left or right, to change the aim of the lens while the camera remains in the same position is called panning (See Fig. 1-5). The command is "Pan right" or "Pan left". There could be more specific commands given such as "Pan right and follow," which would give guidance as to the speed of the movement. Move at the same speed as the subject. There is also the swish pan, or whip pan, which is so rapid that it creates a blur of movement.

A pan, just as any other camera movement, should never be done aimlessly or without good reason. It should have a definite starting and stopping

point, or it should be following something. Whenever possible, there should be some obvious motivation for the movement such as someone in the picture looking off to the side and then the camera making the pan to show what he sees. That won't always be possible, especially in ENG, the coverage of uncontrolled events. In all cases though, have the start and stop points fixed in your own mind. That way, the movement will be decisive and direct.

**Tilt.** The vertical movement of the aim of the camera lens is called tilt. (See Figure 1-5). In the language of television, the command would be "tilt up" or "tilt down." Just as with the pan, tilts should be motivated. Without good reason, any movement takes away from the value of a production. The amount of tilt is more critical than that of the pan, due to the dimensions of the videospace (3 units high by 4 units wide). Since the horizontal dimension of the screen is one third larger than the vertical dimension, there is more room for error in the panning movement, making it even more important to have the start and stop points firmly established in your mind.

**Pedestal.** Similar to the tilt, the pedestal movement is an up and down movement. However, it is not in the aim of the camera, but rather the movement of the camera itself without changing the aim (See Figure 1-5). The command will be "pedestal up" or "pedestal down." The pedestals that studio cameras sit on, as well as the tripods that portable field cameras sit on, have various ways to raise and lower the camera. The tripod you will be using with a portable camera will most likely have some sort of crank handle to raise and lower the camera while the aim remains the same. Quite often, the pedestal movement will be used in conjunction with the tilt movement. When this is the case, there will need to be some sort of explanation previous to the actual execution command. EXAMPLE: "When I give you the command to pedestal up, tilt down at the same time and rate, so we can keep the subject in the picture, but change our shot angle."

**Zoom.** We have discussed the zoom under focal length earlier. The zoom, although a movement, does not constitute movement of the camera or the aim of the camera. The only thing to add at this point is to re-emphasize that any camera movement, particularly zooms, must be motivated. The tendency for beginning videographers is to do a lot of camera moving. They fail to realize that their job isn't to create the action, but to capture on videotape the action already taking place. The command for the zoom is "zoom in" or "zoom out." There is also a special effect called the snap zoom. This is an extremely rapid zoom, either in or out, that is used to emphasize a dramatic point. It is more common in EFP than ENG and

calls attention to itself. The viewer can't help but notice it, and it should be used only for maximum effect.

**Focus.** The commands "zoom focus" and "rack focus" mean specific actions that the operator is to accomplish. A zoom focus is done whenever the situation and time permit. Rack focus is done when there isn't enough time to zoom focus, or for an effect. Another effect with focus that will call the viewer's attention is de-focus. This would be to begin the shot out of focus and bring the subject into focus at a designated time. It could also be done in the reverse by taking the subject out of focus to bring something else in the videospace into focus, or merely to indicate the end of the need to see the subject.

**Dolly.** Dolly is the movement of the camera toward or away from the subject (See Figure 1-5). The commands to dolly are, "dolly in" or "dolly out."

**Crane.** A crane is the movement of the camera atop a long arm of a crane. Also called a boom, this is another function that is more common in EFP. The command is "crane up," or "crane down." When referred to as a boom, it would be "boom up," or "boom down."

**Truck.** Truck is the movement of the camera to the right or left while keeping the aim of the camera generally the same (See Figure 1-5). Just as there is a difference between a tilt and a pedestal, there is a big difference between a pan and a truck. If a subject was traveling horizontally across the videospace and the operator just panned to follow it, the shot angle would change. By trucking we keep the angle of camera to subject the same. The command is "truck right," or "truck left." To truck to one side or the other for more than just a short distance is called a "tracking" shot. It is used most commonly in motion pictures and sometimes in EFP when the camera is going along (usually on tracks for stability) next to a moving subject. EXAMPLE: The interplay of driver and shotgun rider on a stagecoach when the scenery is flying by and the subjects remain in the same spot in the videospace.

**Arc.** An arc can be either a combination of truck and dolly in a straight line to arrive at a prescribed point, or a semi-circular movement to one side or the other (See Figure 1-5)

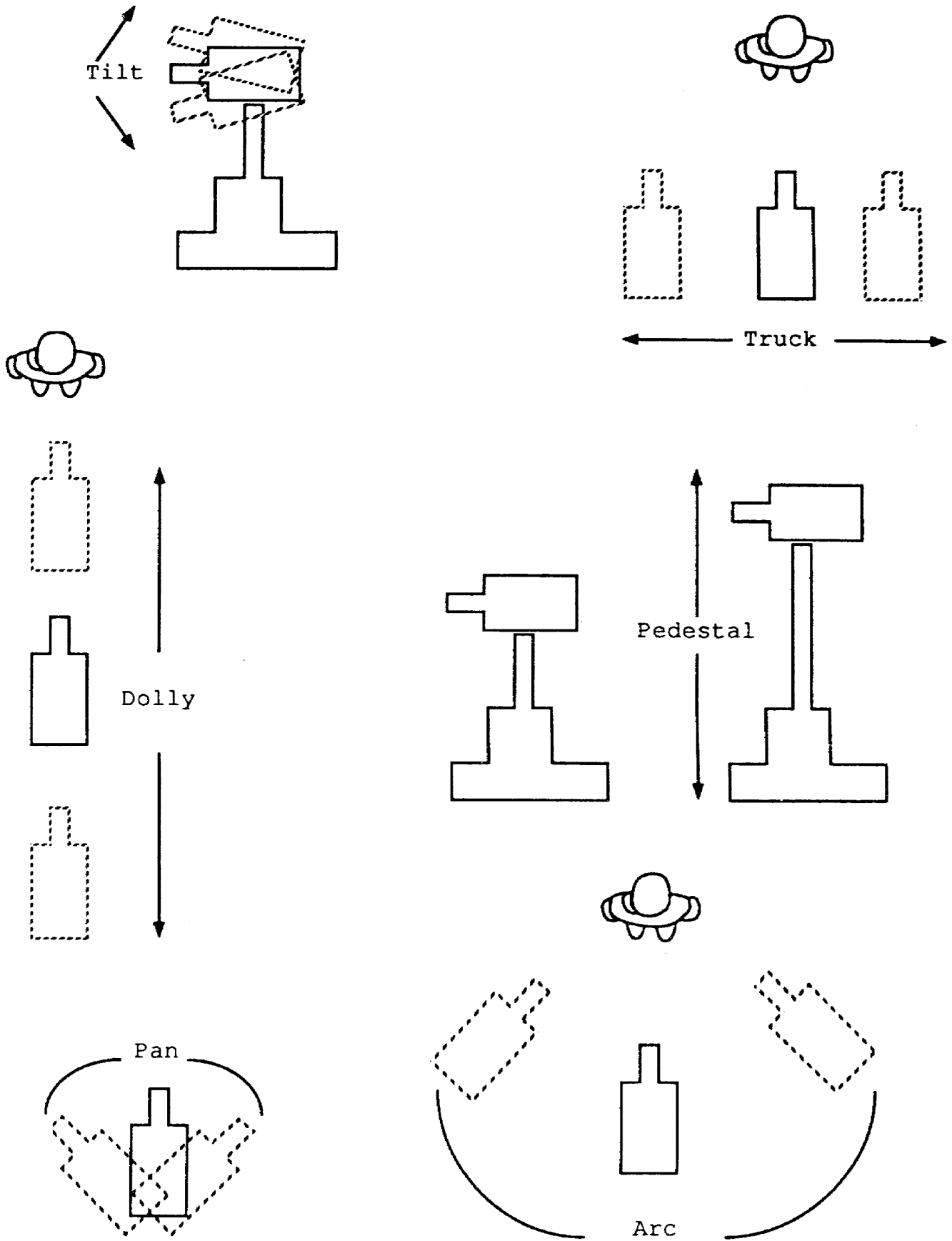

FIGURE 1-5. CAMERA MOVEMENT

The command is "arc right" or "arc left." Most often an arc is used to provide another angle of a subject while allowing the viewer to see the change of angle taking place. In some motion pictures, you may even have seen an arc go completely around a subject.

All of the camera movements and their commands apply to both studio and portable camera operation. There are some things however, that you should keep in mind when operating the portable ENG camera.

- o If you are not operating a one-piece cam-corder you must be certain that your connections to the recorder are secure and that both pieces of equipment are moved in unison.
- o Check your mounting plate and be sure not only that the camera is mounted securely to the plate, but also that the plate is mounted securely to the tripod.

Now that you know the different camera movements and what they are called, you must realize that the need for these movements comes about because your viewers rely on you to provide a visually understandable product. What you put into the videospace is important, but how you put it there is just as important. You learned the basics of framing and composition in Subcourse DI0350, Electronic Journalism. There are two different points of view that you should take regarding proper framing and composition: that of the videographer, and that of the editor. You need to know how to do both. There will be times when you will shoot for someone else to edit, and times when you will edit someone else's video. When you're shooting video, you must keep the editing process in mind whether or not you will be the one who edits the final product.

**EXAMPLE:**

If you are zooming in or out on a subject, you may want to do it several times, taking different lengths of time for each. One five-second zoom-in, a ten-second zoom-in and even a snap zoom. That way, the editor will have a choice of zooms to use.

When you log the video, you must speak the language of television on the chance that someone else may have to edit it. The following two examples are different ways of logging the same B-roll tape. Compare them side by side. If you were the editor, which of them would you want to have provided to you?



EXAMPLE ONE

00:00 - 00:12 LONG SHOT (LS) ESTABLISHING SCENE OF BUILDING ON FIRE

00:12 - 00:48 LONG SHOT (LS) OF FIRE TRUCK ENTERING FROM RIGHT, MEDIUM SPEED PAN LEFT TO WHERE TRUCK STOPS TO BEGIN FIGHTING FIRE

00:48 - 01:32 QUICK ZOOM IN TO MEDIUM SHOT (MS) OF MEN JUMPING OUT OF TRUCK AND RUNNING TO UNLOAD EQUIPMENT

01:32 - 02:10 MEDIUM CLOSE UP (MCU) OF WINDOW WITH FLAMES LEAPING OUT AND RUNNING UP WALL

02:10 - 03:30 MEDIUM SHOT (MS) REAR OF FIRE TRUCK WITH MEN TAKING HOSE OUT. MEN LEAVE FRAME AND HOSE COMES OUT OF TRUCK

03:30 - 04:45 CLOSE UP (CU) OF HANDS TAKING CAP OFF OF FIRE HYDRANT AND CONNECTING HOSE

04:45 - 05:05 EXTREME CLOSE UP (ECU) OF WRENCH TURNING ON WATER AT FIRE HYDRANT

05:05 - 05:20 CLOSE UP (CU) OF NOZZLE OF HOSE WITH NO WATER COMING OUT - THEN WATER COMES OUT

05:20 - 07:30 MEDIUM LONG SHOT (MLS) OF WATER BEING SPRAYED ON BUILDING

07:30 - 08:25 MEDIUM CLOSE UP (MCU) OF WATER GOING IN WINDOW WITH FLAMES LEAPING OUT

08:25 - 09:15 MEDIUM CLOSE UP (MCU) GROUND LEVEL OF HOSES LAYING ON GROUND - FOCUS ON HOSE IN FOREGROUND CHANGING TO HOSE IN BACKGROUND AND EVENTUALLY THE FIRE TRUCK

09:15 - 09:30 EXTREME CLOSE UP (ECU) OF FIREMAN'S FACE - EYES LOOKING UP AT 45 DEGREE ANGLE - FLAMES REFLECTING ON SKIN AND FIRE HAT

09:30 - 09:38 LONG SHOT (LS) OF ROOF CAVING IN

09:38 - 10:10 MEDIUM LONG SHOT (MLS) FIREMAN BEING PULLED FROM BUILDING - CAMERA DOLLY IN TO (MCU) OF FIREMAN RECEIVING TREATMENT

10:10 - 12:02 MEDIUM SHOT (MS) FIREMAN BEING LOADED INTO AMBULANCE - DOORS BEING CLOSED - AMBULANCE LEAVING SCENE, LEAVES FRAME

EXAMPLE TWO

00:00 - 00:12 SCENE OF BUILDING ON FIRE

00:12 - 00:48 FIRE TRUCK ENTERING FRAME, STOPS TO  
BEGIN FIGHTING FIRE

00:48 - 01:32 MEN JUMPING OUT OF TRUCK AND RUNNING TO  
UNLOAD EQUIPMENT

01:32 - 02:10 WINDOW WITH FLAMES LEAPING OUT AND  
RUNNING UP WALL

02:10 - 03:30 REAR OF FIRE TRUCK WITH MEN TAKING HOSE  
OUT. SHOT REMAINS STEADY AS HOSE COMES  
OUT OF TRUCK

03:30 - 04:45 HANDS TAKING CAP OFF OF FIRE HYDRANT AND  
CONNECTING HOSE

04:45 - 05:05 WRENCH TURNING ON WATER AT FIRE HYDRANT

05:05 - 05:20 NOZZLE OF HOSE WITH NO WATER COMING OUT  
-THEN WATER COMES OUT

05:20 - 07:30 WATER BEING SPRAYED ON BUILDING

07:30 - 08:25 WATER GOING IN WINDOW WITH FLAMES  
LEAPING OUT

08:25 - 09:15 HOSES LAYING ON GROUND - FOCUS ON HOSE  
IN FOREGROUND CHANGING TO HOSE IN  
BACKGROUND AND EVENTUALLY THE FIRE TRUCK

09:15 - 09:30 FIREMAN'S FACE - EYES LOOKING UP AT 45  
DEGREE ANGLE TO BUILDING - FLAMES  
REFLECTING ON SKIN AND FIRE HAT

09:30 - 09:38 ROOF OF BUILDING CAVING IN

09:38 - 10:10 FIREMAN BEING PULLED FROM BUILDING -  
FIREMAN BEING GIVEN EMERGENCY MEDICAL  
TREATMENT - SOME CHANGE OF FOCUS DURING  
SEQUENCE

10:10 - 12:02 FIREMAN BEING LOADED INTO AMBULANCE -  
DOORS CLOSE - AMBULANCE LEAVES SCENE

Proper equipment operation is essential to ENG. It includes thinking far beyond just building the videospace. Since the electronic news gatherer is often camera operator, director, lighting director, gaffer, writer, editor and audio engineer he must be able to correctly operate all of the equipment.

So far you have learned how to operate the camera. Part of that operation is to keep in mind the points you must consider to shoot anything from a feature to a spot news story. Don't forget what you learned in Lesson Three, Framing and Composition, subcourse DI0350. Good shot composition, variance of angles, lead room and transmission loss will all come into play in all the video you shoot.

### **LIGHTING EQUIPMENT**

You learned the principles of television lighting in Subcourse DI0350. Operation of equipment is nothing more than applying those principles. It may help you to review Lesson Two of DI0350.

### **RECORDING EQUIPMENT**

Just as with the technical aspects of camera operation, you will have to refer to the operator's manual for the proper setup and use of your recorder. There are a few points you must remember about the use of any recorder:

- o Plug your primary audio microphone into channel two and your natural sound or background microphone into channel one. Channel two is on the inside of the tape, and protected from edge damage.
- o Plug in your headphones and listen to the audio you record. Don't just assume you are recording what you want and in the balance you want it.
- o If your recorder is not the type that is connected to the camera body, be sure the cables connecting the two are secure, and are not where someone passing by will trip over them.
- o Record some video and play it back to make sure the camera and recorder system are functioning properly.

Remember, you can always eliminate unwanted audio and video in the editing process. You can't always create the audio or video you need if it isn't there. In the operation of the recording equipment, the key is to make sure you record all you need while on the scene of the event.

A final point to remember is that along with the operation of ENG equipment must go proper care of that equipment. It is each crew member's responsibility to make sure each piece of equipment receives the best of care at all times.

PRACTICE EXERCISE

LESSON 1

SUBCOURSE NO. DI 0351

OPERATE ENG EQUIPMENT

INSTRUCTIONS:

Review the material in this lesson. Answer the questions below by circling the "T" or "F" next to each question.

Compare your answers with the answer key on the next page.

- T F 1. Whenever camera movement is called for, the camera operator should already have the start and stop points fixed in his mind.
- T F 2. Once a good, smooth zoom has been accomplished, while videotaping in the field, it's not a good idea to waste tape by trying it again.
- T F 3. Rack focus is another term for zoom focus.
- T F 4. There are three major parts to a portable television camera: the lens, the body, and the viewfinder.
- T F 5. The degree to which you can change the focal length of a zoom lens is called the zoom range.
- T F 6. Since sports is usually a segment of the news, coverage of a sporting event is considered electronic news gathering.
- T F 7. All portable television cameras have to have a four-position filter disc.
- T F 8. A good camera operator concentrates on getting the good shots and doesn't concern himself with editing.
- T F 9. The camera lens is sometimes called the internal optical system.

ANSWER KEY

PRACTICE EXERCISE

LESSON 1

SUBCOURSE NO. DI 0351

OPERATE ENG EQUIPMENT

1. TRUE (Page 10)
2. FALSE (Page 13)
3. FALSE (Page 11)
4. TRUE (Page 3)
5. TRUE (Page 5)
6. FALSE (Page 2)
7. FALSE (Page 4)
8. FALSE (Page 13)
9. FALSE (Page 5)

## LESSON TWO

### SELECT AND SET UP MICROPHONES

46R Soldier's Manual Task 214-177-1201

#### OVERVIEW

#### LESSON DESCRIPTION:

This lesson will provide you an overview of selecting and setting up microphones.

#### TERMINAL LEARNING OBJECTIVE:

**ACTION:** Describe procedures necessary to properly select and set up microphones for electronic news gathering productions.

**CONDITION:** You are given the material presented in this lesson.

**STANDARD:** Perform all duties described in this lesson.

**REFERENCES:** The material contained in this lesson was derived from the following publications:

STP 46-46R14-SM-TG Soldier's Manual & Trainer's Guide,  
Broadcast Journalist, MOS 46R Skill Levels 1/2/3/4, August  
1988.

Defense Information School Radio and Television Handbook,  
May 1982.

## SELECT AND SET UP MICROPHONES

### INTRODUCTION

According to Webster's Ninth New Collegiate Dictionary, the definition of television is: an electronic system of transmitting transient images of fixed or moving objects together with sound over a wire or through space by apparatus that converts light and sound into electrical waves and reconverts them into visible light rays and audible sound. Too often those involved in the production of television have thought of it as a visual medium and forgotten that half of it is sound.

Regardless of how good the video is, if the audio is weak, so is the production. You should plan and produce the audio with the same care and attention to detail as the video.

### WHAT IS SOUND?

Before discussing the selection and setup of microphones, it's necessary to say something about the characteristics of sound. In this lesson, we'll stay very basic and give you only what you need to know to perform on a satisfactory level. Of course, if you want to learn more about sound, it will enhance your proficiency.

Sound occurs when a body vibrating back and forth creates pressure variations which are pushed outward in waves through the air. These waves travel away from the source equally in all directions, much like the ripples in a pond caused by something striking the surface.

Many things can affect sound waves, just as many things can affect the ripples in a pond. When we talk about sound from a production standpoint, we are referring to how the sound is perceived by the human ear after it has been affected by all the external influences. Also, there are important differences between the physical properties of sound and how we actually hear it. All the various factors involved would be too detailed to discuss now, but there are two important factors you should be familiar with to work with television audio. They are sound frequency and sound intensity.

### Sound Frequency

The sound waves of a vibrating body go in cycles and can be illustrated by a "sine wave" (See Fig. 2-1 Sound Waves).

Each cycle is measured from the beginning of one wave to the beginning of the next. The number of complete waves, or cycles, per second determines

the frequency of the sound. This is called hertz (Hz). That is why a thousand cycle tone is the same as a thousand hertz tone. The height of the waves is the amplitude, or loudness. We measure this in decibels (dB).

The faster the vibration of the body, the more cycles produced and the higher the pitch of the sound. For example, the number of cycles per second produced by a train's whistle is far greater than the number of cycles per second produced by a ship's fog horn. They may both have the same intensity, but they have very different pitch. The human ear can perceive from 16 Hz to 16,000 Hz. Of course, some people hear better than others, but this is the general range. Normal hearing is most sensitive to sounds between 500 Hz and 4,000 Hz. This is the range of sound frequency most important for understanding speech. Professional audio equipment is capable of reproducing sound frequencies from about 16 Hz to 20,000 Hz, which is the full audio spectrum necessary to pick up and reproduce sound and music accurately.

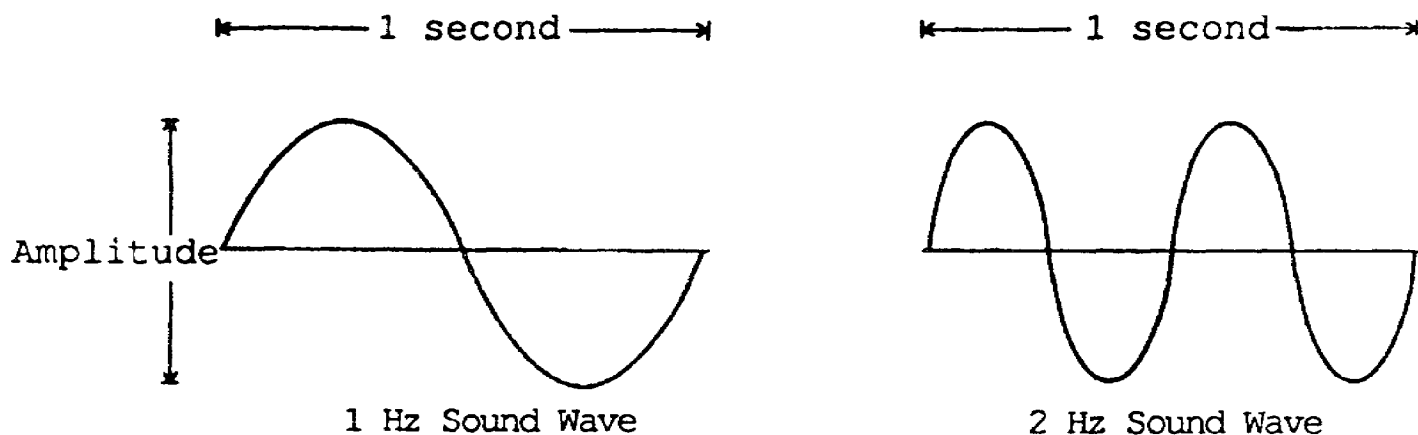

FIGURE 2-1. SOUND WAVES

### Sound Intensity

Sound intensity is directly related to the amount of energy expended in creating the vibrations. For example, the harder you hit a drum, the louder it sounds. The increase of pressure through a whistle increases



the loudness of the sound. In both cases, the pitch remains the same, but the volume goes up.

As previously mentioned, loudness or sound intensity is measured in decibels (dB). It's also important for you to understand how the decibel scale works. We sense the difference in two sounds by comparison rather than by a particular measurement. You can't tell how many decibels a sound is just by listening, but you can tell which of two sounds is louder.

The decibel scale is a logarithmic scale. A doubling of the intensity is represented by an increase of 3 dB. In other words, whenever we double or halve the intensity of a sound, we change it by 3 dB. A change from 3 to 6 dB is doubling the sound intensity. A doubling of 9 dB would not be 18 though. It would be 12. (An increase of 3.) And of course, the same goes for lessening the loudness.

You should be familiar with the decibel scale because it is often used in audio production to refer to audio levels. The common VU meter on audio boards is calibrated in decibels and percentage of modulation (See Fig. 2-2 Volume Unit Meter).

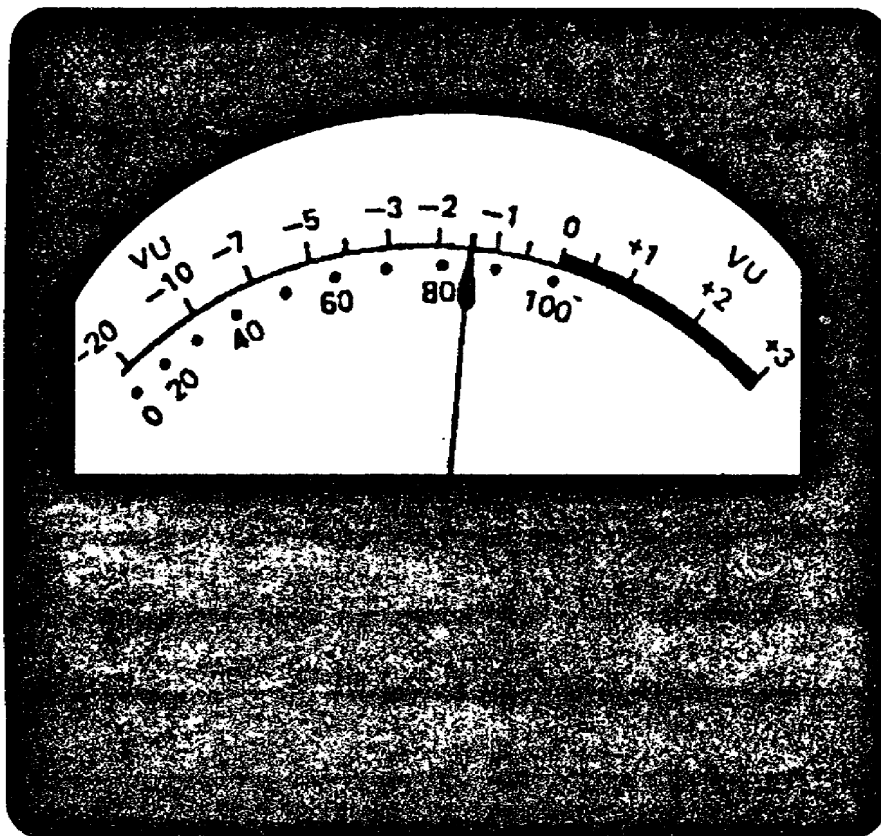

FIGURE 2-2. VOLUME UNIT METER

## TYPES OF MICROPHONES

There are two basic parts common to all microphones: The diaphragm and the generating element. The diaphragm is a flexible device, sensitive to the air pressure variations created by sound waves. The generating element is attached to the diaphragm, and converts the vibrations into electrical energy. This is not unlike the camera lens and the camera, where the lens captures the visual images and the camera converts them into electronic signals (See Figs. 2-3, 2-4 & 2-5 Microphones).

### Selecting The Correct Microphone

Begin by conducting an acoustical analysis. You do that by assessing how audio will carry or be distorted in the recording environment (e.g., studio, empty room, room filled with furniture, small room, room with high ceiling, outdoors, etc.). While doing this, keep in mind the microphone types and pickup patterns of the microphones available. Then take into consideration any possible audio problems. This applies to both your ENG and your EFP work. Think not only about the primary audio and the equipment required to best achieve the required result, but about the background audio, or wild sound as well. Select the type of microphone that will provide the best pickup for the situation. There are three primary types of microphones you will deal with: Dynamic, Ribbon and Condenser.

The *DYNAMIC* microphone is durable and excellent for outdoor use as a production microphone. This type of microphone is the least vulnerable to distortion and the most common in use in ENG. (See Fig. 2-3, Dynamic Microphone)

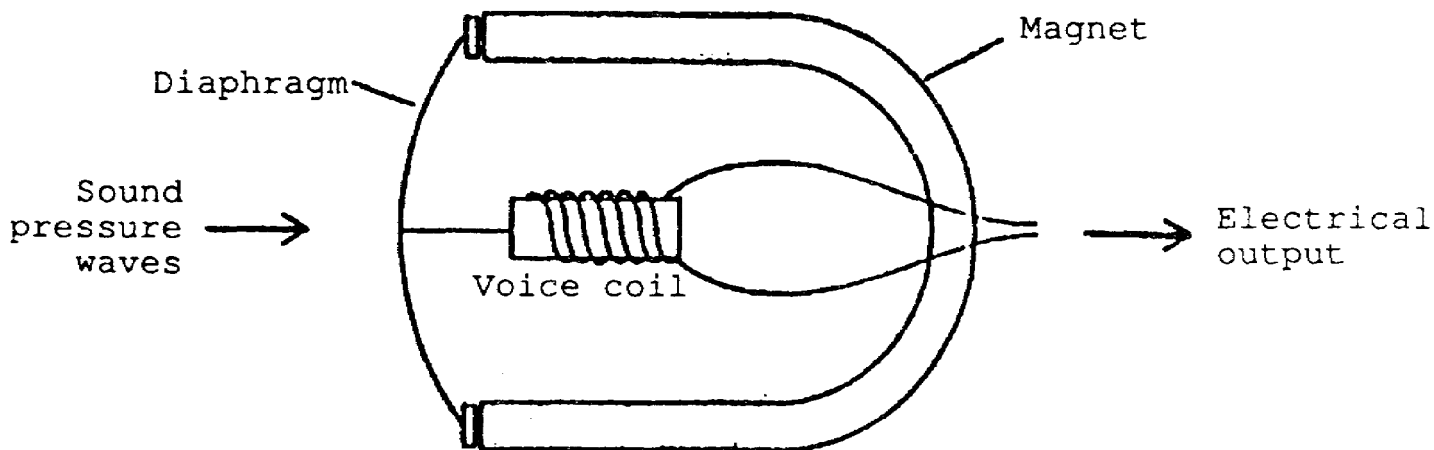

FIGURE 2-3. DYNAMIC MICROPHONE

The *RIBBON* microphone is fragile and sensitive to strong, loud or sudden sounds that can damage the ribbon. This microphone should be used indoors. It is desirable for use on announcers, singers and musical instruments. It's not as good for ENG since you'll need more control over separation. You'll need to separate primary audio and wild sound more than this microphone will permit. Remember too, you have little or no control over strong, loud or sudden sounds outside the studio that would harm the ribbon microphone. (See Fig. 2-4, Ribbon Microphone)

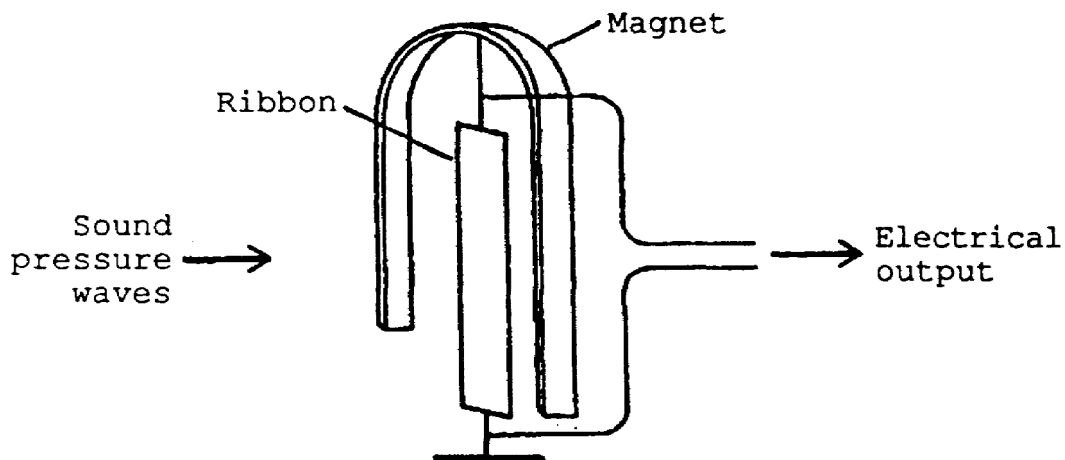

FIGURE 2-4. RIBBON MICROPHONE

The *CONDENSER* microphone generates a low signal and needs a pre-amplifier to boost its strength. It requires a separate power supply, which is large and bulky. This makes the use of this microphone difficult for ENG since one of the main concerns of the ENG team is to lessen the amount of equipment rather than add to it. The condenser microphone provides the highest quality of sound of the three types of microphones. Although it is too sensitive for outdoor use, it is excellent for music pickup. Its use in ENG/EFP would be limited to something such as a video spot for the U.S. Army Band. (See Fig. 2-5, Condenser Microphone)

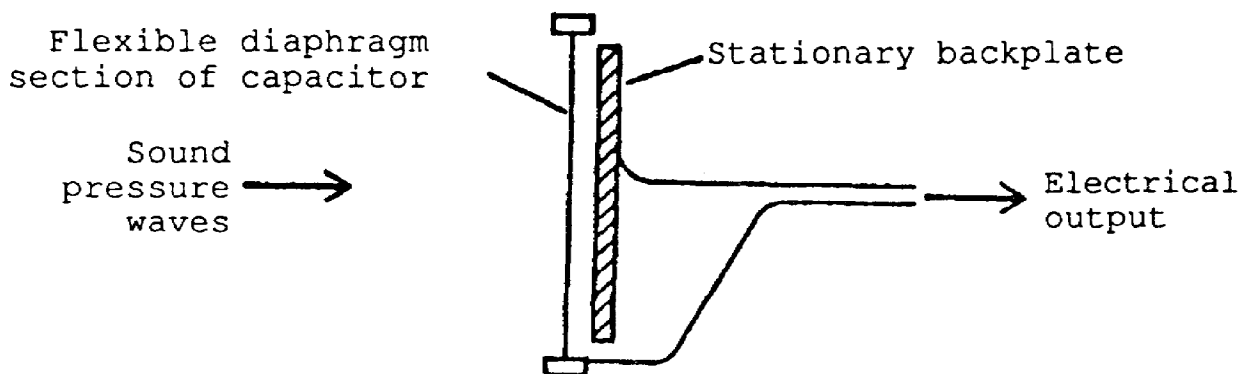

FIGURE 2-5. CONDENSER MICROPHONE

## PICKUP PATTERNS

When selecting the microphone, consider the various pickup pattern of each microphone.

The *OMNIDIRECTIONAL* microphone picks up sounds coming from any direction equally well. This microphone is recommended when one microphone must cover a wide area or when unwanted noise is not a problem (See Fig. 2-6 Pickup Patterns).

The *UNIDIRECTIONAL* microphone picks up sounds coming from one direction and suppresses sounds coming from the rear and sides. It is recommended if unwanted noise is a problem. Unidirectional pickup patterns have three general categories: bidirectional, Cardioid, and supercardioid (See Fig. 2-6, Pickup Patterns).

The *BIDIRECTIONAL* microphone picks up sound coming from directly in front and in back. This microphone is not good for television because it picks up studio noises. It is good for two people who face each other, as in the old radio drama, but in television the side opposite the performer is usually the camera and behind the scenes (See Fig. 2-6, Pickup Patterns).

The shape of the *CARDIOID* pickup pattern is similar to that of a heart, as you would suspect from its name. Most cardioid microphones are sensitive to about 120 degrees on either side of straight forward, although this can vary somewhat. The advantage of some directional isolation in addition to a wide audio pickup range makes this a good microphone for television. Even when the performer is some distance away from this microphone, it will produce better quality sound than an omnidirectional microphone.

The *SUPERCARDIOID* is the most highly directional pattern, and is designed to pick up sound within a very limited range. Often called a shotgun microphone, the biggest drawback to this type of microphone pickup pattern is its highly unidirectional shape. Unless the microphone is pointed directly at the sound source poor audio quality will result. Its advantage is in its ability to pick up sound at far greater distances (See Fig. 2-6, Pickup Patterns). Even though it is designed to pick up sound at greater distance, the closer the source, the better the sound that will be reproduced.

The points to remember when considering the pickup patterns of each microphone are the desired mixing or separation of sounds for the production, the likelihood of unwanted sounds occurring during shooting and the amount of gear to be transported to the shoot site. There is really no best microphone pickup pattern. Each is designed for a

particular situation. The trick is to let the microphone's pickup pattern work for you by focusing on the sound you want and eliminating the sound you don't want. An interview taking place next to a busy highway, for example, would be better conducted with a unidirectional rather than an omnidirectional microphone (See Fig. 2-6, Pick-up patterns).

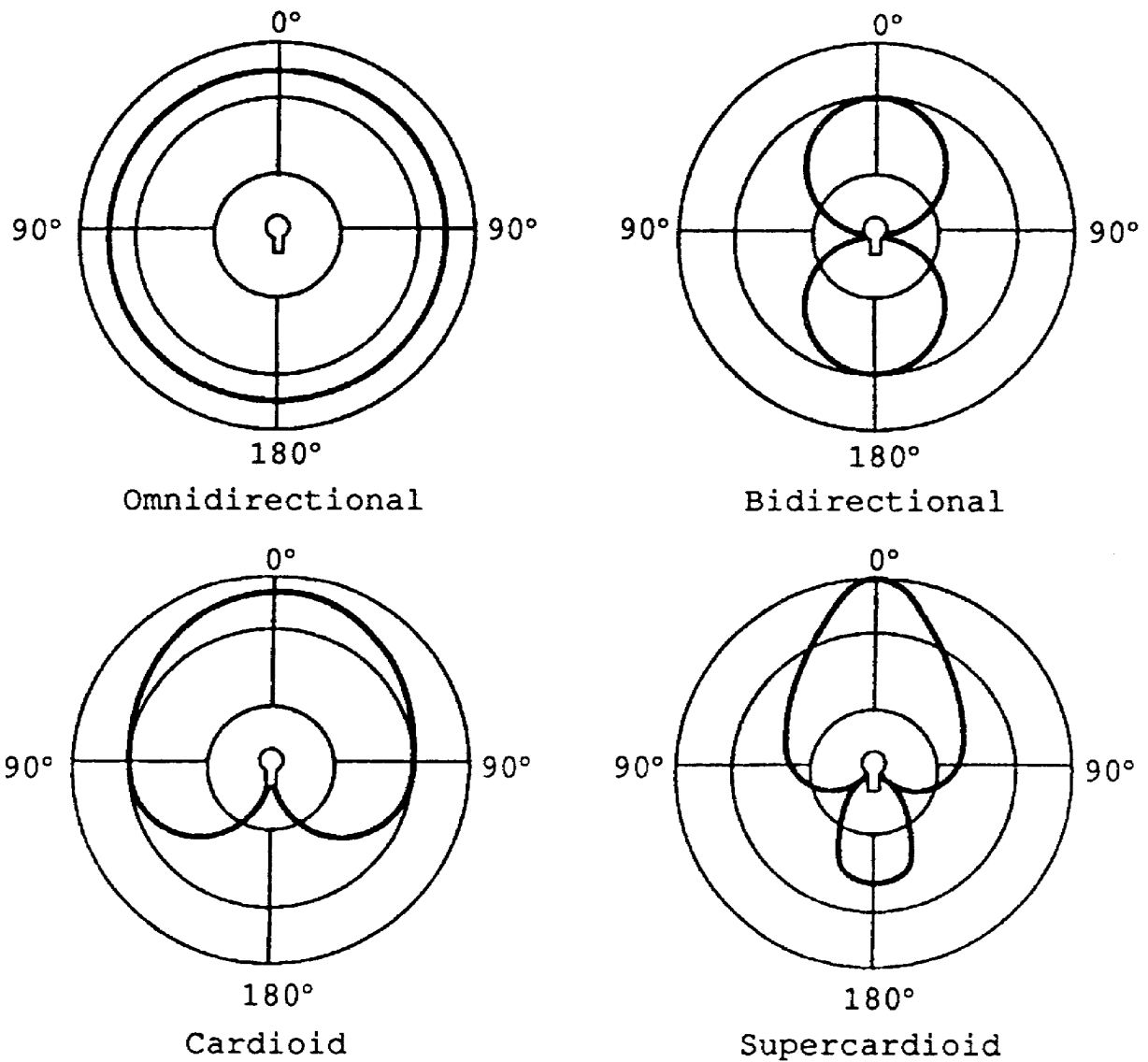

FIGURE 2-6. PICK-UP PATTERNS

**IMPEDANCE**

Another important factor for you to understand about microphones is impedance. Impedance is the amount of resistance in a circuit. Low impedance means little resistance and a greater current flow, while high impedance means greater resistance and lesser current flow. The numbers are not important for you, as an operator, to know. They are more important to engineers, but you need to understand two important facts: Low impedance microphones permit the use of long cables without

significant loss of signals, and a microphone's impedance must always match the input connector impedance on a tape recorder or audio mixer. That means if your recorder uses a high impedance input connector, you will have to use a high impedance microphone, and therefore, a relatively short cable of approximately ten feet or less, or a transformer designed to match the low impedance of the microphone and the high impedance of the recorder. Of course, this will be of more concern to the ENG team chief than it will to the videographer, but remember, you could very well be both.

## **PLACEMENT OF MICROPHONES**

Another consideration when selecting a microphone is its placement. This is dictated by the subject or situation. Since we're talking about video, the appearance of the microphone is also important to consider. Very often when an interview takes place, the microphone has a flag (little symbol that identifies the station or unit producing the piece) in view of the camera. Of course, it shouldn't be a distraction.

The *LAVALIÈRE* microphone is most commonly used for studio television, but can sometimes be used in the field when it is necessary for the talent to have his hands free. It is always omnidirectional, and the speaker talks across, rather than directly into it. It should be placed on the lapel in the direction the performer will face and NOT under any clothing. Production personnel should place the microphones on non-professional talent. A guest who puts on his own microphone will worry about how it looks instead of sound quality.

The *DESK* microphone is positioned in the direction the talent will face on a desk or tabletop. It is sensitive to desk noise. Use a foam rubber pad under the microphone stand to eliminate some of this problem.

The *HAND* microphone is commonly used for television reporting in the field. The interviewer has complete control over positioning because he is holding the microphone. A backup to this microphone could be a BOOM microphone suspended above the sound source. It can be suspended mechanically or handheld.

The *STAND* microphone is basically a hand microphone positioned on a stand and therefore quite common in ENG/EFP. On a stand it is used by singers or near musical instruments.

The *HEADSET* microphone is used when an off-camera announcer needs to have his hands free. It's used frequently for sporting events, which are EFPs.

The *WIRELESS* microphone is any small microphone with a battery-powered transmitter. It does not have a cord, and allows for free movement.

The *SHOTGUN* microphone is a long, tubular microphone and is highly unidirectional, (Remember the supercardioid pickup pattern). It can be several feet from the speaker. This microphone locks in on the main source of sound while eliminating extraneous noise. It is very useful when you can't get near the source.

## **CABLES AND CONNECTORS**

In most cases, the output of microphones must travel through a cable in order to reach the recorder. This requires the use of special audio cables, connectors and receptacles. We'll talk about them separately.

### **Cables**

An audio cable is two wires inside protective insulation. At each end is a connector. The exception is the lavalier microphone. The lavalier is connected permanently to its cable and there is only one connector on the other end of the cable. On most others -- hand, desk, stand, and boom microphones -- there is no permanently attached cable, but a female receptacle in which to plug a cable.

Cables have a natural coil or curve to them. You should follow it when you wind them up for storage. Failure to do so can result in damage to the wires inside the cable and cause audio problems. It is never a good idea to wind the cable around your elbow. It is also not a good idea to tie the cable off by its ends. Twist ties or pipe cleaners work well for holding the cable together.

When running audio cable, always have sufficient length for any movement that may be necessary. It's also a good idea to have a minimum of cable visible in your picture. Avoid stepping on your audio cable and take the necessary measures to prevent others from doing so as well.

### **Connectors**

Professional microphones and cables use a standard connector called a cannon plug. It is actually a cannon XLR with three-pronged male and

female plugs, (See Fig. 2-7, Microphone Connector Plugs). Most audio outputs use a male plug and most inputs use a female receptacle. They lock into position when connected. This is a safety precaution to make sure they don't come apart during use. The male plug has a release button that must be pushed to disconnect.

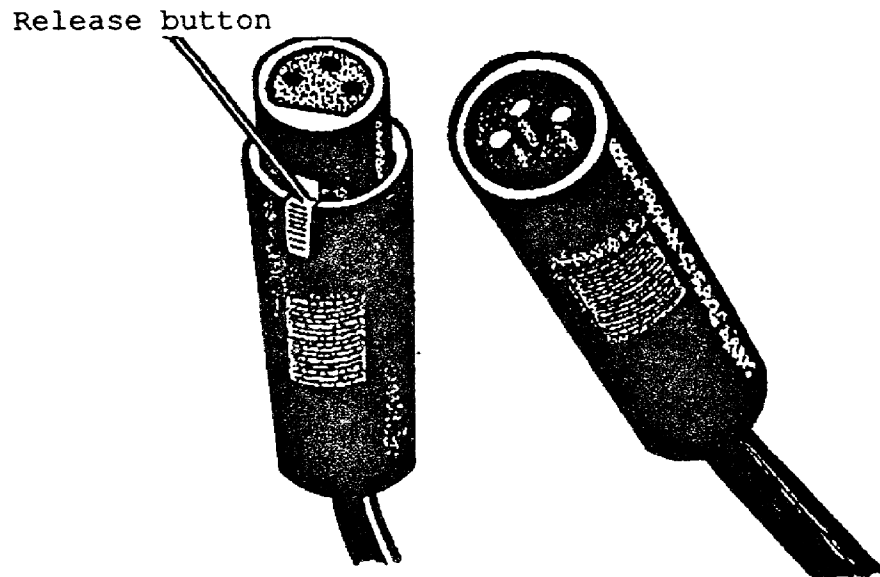

FIGURE 2-7. MICROPHONE CONNECTOR PLUGS

## WIRELESS MICROPHONES

Wireless microphones, as the name implies, operate without any cables. They give you all the advantages of a lavalier or hand microphone without the restrictions of cables.

The wireless microphone is a conventional lavalier or hand microphone connected to a small battery-powered transmitter. The signal is transmitted through a small antenna on an FM radio frequency to a receiver. The output of the receiver can then be fed into a camera, a recorder or an audio console.

Many hand-held wireless microphones have the battery and transmitter in the microphone case. You may have seen singers performing into a microphone with a little antenna protruding from the bottom of the case. The transmitter and battery for wireless lavalier microphones are in a pocket-sized unit that is easily carried by the performer while allowing his hands to remain free. This can be beneficial in any number of applications.



Early models of the wireless microphone were subject to interference from many sources, such as taxi and police radios. Newer RF microphones use a diversity receiving system which is designed to prevent those problems. Wireless microphones with the diversity receiving system are reliable and dependable.

The transmission range of wireless microphones is anywhere from 50 to 1000 feet depending on conditions. Of course, you'll want to position your receiver as close to the microphone as you can.

The one disadvantage of the wireless microphone is cost because a separate transmitter and receiver is required for each microphone. The advantages of freedom of movement and increased range, may or may not be worth the expense.

### **FILTERS**

Microphones are susceptible to loud, sudden sounds and wind noise. Pop filters and screens are used on microphones to diminish these sounds. Pop filters are built-in, usually in dynamic microphones. They are excellent against distortion. Windscreens are externally mounted but cannot eliminate loud distortion. Filters are most used when reporting in the field.

### **THE RIGHT TOOL FOR THE JOB**

Determine the number and type of microphones, cables and filters needed. Base this upon the information provided to you in the script, your acoustical analysis, and your decision on the type, pickup pattern, and position(s) of your microphone(s). The types of microphones you use and their positioning will be based on your subject and the situation.

### **THERE'S MORE TO IT**

For ENG we must also consider spare microphones and cables. Carry this a step further and be sure you have spares for any of your equipment. Once you're out in the field, you won't have the chance to run into the equipment cabinet to replace a burned out bulb, or an audio cable that doesn't work. Check all of your audio equipment. Speak into or across each microphone in a normal voice. If any are not working, check the connector cables and make sure the microphones are switched "ON." If a microphone doesn't work, replace it. If audio feedback or interference occurs, reposition the microphones until the problem is eliminated.

Do this in the station/studio/office. Then take spares along anyway. Just as with all the equipment necessary for the production, your checklist should include spares for any equipment that could malfunction and keep you from completing your mission.

Finally, there is no substitute for planning in ENG and EFP. Audio is as much a part of any ENG/EFP piece as video even if it's only natural or background sound. After all the planning it is still important to not take shortcuts while shooting. Use the headsets to actually hear the audio that is being recorded. Don't take-for granted that it'll be there and spend all your efforts on video only. Once the event has taken place and you return to your editing suite, there is no going back for something you missed, and if you don't have everything, including audio, all your time and effort is wasted.

PRACTICE EXERCISE

LESSON 2

SUBCOURSE NO. DI 0351

SELECT AND SET UP MICROPHONES

INSTRUCTIONS:

Review the material in this lesson. Answer the questions below by circling "T" or "F" next to each question. Compare your answers with the answer key on the next page.

- T F 1. Audio is the one area of ENG where you can afford to take shortcuts.
- T F 2. A shotgun microphone is also called Bidirectional.
- T F 3. All ENG microphones have a diaphragm.
- T F 4. Modern wireless microphones are still subject to interference from taxi and police radios.
- T F 5. Sound frequency is measured in decibels.
- T F 6. Sound is pressure variations in the air which travel in waves.
- T F 7. Sound amplitude is measured in hertz.
- T F 8. A VU meter is calibrated in decibels.
- T F 9. Omnidirectional means only in one direction.
- T F 10. Some microphones have built-in filters.

ANSWER KEY

PRACTICE EXERCISE

LESSON 2

SUBCOURSE NO. DI 0351

SELECT AND SET UP MICROPHONES

1. FALSE (Page 31)
2. FALSE (Page 25)
3. TRUE (Page 23)
4. FALSE (Page 30)
5. FALSE (Page 21)
6. TRUE (Page 20)
7. FALSE (Page 21)
8. TRUE (Page 22)
9. FALSE (Page 25)
10. TRUE (Page 30)

## LESSON THREE

### PREPARE/PERFORM TV NEWS INSERTS

46R Soldier's Manual Task: 214-177-1311

#### OVERVIEW

#### LESSON DESCRIPTION:

This lesson will provide you an overview of preparing/performing television news inserts.

#### TERMINAL LEARNING OBJECTIVE:

- ACTION:** Describe procedures necessary to properly prepare/perform television news inserts.
- CONDITION:** You are given the material presented in this lesson.
- STANDARD:** Perform all the duties described in this lesson.
- REFERENCES:** The material contained in this lesson was derived from the following publications:

STP 46-46R14-SM-TG Soldier's Manual &  
Trainer's Guide, Broadcast Journalist,  
MOS 46R Skill Levels 1/2/3/4, August 1988.  
Defense Information School Radio and  
Television Handbook, May 1982.  
Defense Information School, Broadcast  
Journalism Style Guide

## **PREPARE/PERFORM TV NEWS INSERTS**

### **INTRODUCTION**

The preparation and performance of television news inserts are the meat and potatoes of the electronic journalism business today. This is true in both the civilian and military worlds. In the civilian world, there are entire networks concerned with news only, (and advertising, of course). The public affairs mission of the Army is divided into public information (PI) and command information (CI), both of which can often best be served in a news format.

Your role as videographer, (already covered in the operation of ENG equipment under camera operation), writer, announcer, editor, director or assignments manager will require you to know a lot about the preparation and performance of television news inserts. In this lesson, we'll address the things you'll need to know for announcing, writing, scripting, interviewing and editing. What you'll need to know about assignments manager responsibilities will be covered latter in this subcourse.

### **WRITING**

Writing and scripting, although two slightly different elements, are so closely related that we'll cover them together. Of course, all the principles covered previously under announcing, even though they were mostly aesthetic elements, will still apply and we'll be mentioning them again. Now we'll pay more attention to the mechanics. Some things may seem redundant to you, and they probably are. Remember, we have already talked about a lead, for example. We talked about what it is supposed to accomplish, the two basic types of leads and so forth. When we again talk about leads, even though we will be stressing the mechanics, we'll again touch on some of the aesthetics of them.

### **Procedures and Limitations**

The ability to write comes from much learning and practice. It's difficult, if not impossible, to teach someone to write, much less write well, in one short lesson. The efforts of this lesson will be directed toward giving you the rules that must apply to broadcast writing and how it differs from writing for print media. The best way to learn to write is to -- write, write, write. It also helps to read a lot. Observe the writings of others.

When writing for broadcast, you should apply six "C's". They are; **CLEAR, CONCISE, CONVERSATIONAL, COMPLETE, CURRENT,** and most importantly, **CORRECT.** Let's address each of these points, one at a time.

**Clear.** Broadcast copy must be clear. If something isn't clear, the reader, listener/viewer won't understand it, and he can't go back over it since it's being read to him by someone else, who isn't going to repeat it. Once gone, it's gone forever.

**Concise.** Writing concisely adds to clarity and saves air time, allowing two or three more stories to be included in a 30-minute newscast.

**Conversational.** The copy is going to be read to its intended audience and it should be done in a conversational manner, something that would be possible only if the copy were conversational in the first place. Read it aloud before you turn it in to your editor or air it yourself.

**Complete.** Your writing must answer all the pertinent questions --the who, what, when, where, why and how. News stories should answer questions, not raise them.

**Current.** Here again, there are some exceptions, although usually even when something is presented as being of or about another time, it is presented as in the present. For example, even if we receive something that is of a historical nature, we perceive it in the here and now. We never lose sight of the fact that that's where we are, so the copy shouldn't either.

**Correct.** The importance of being correct cannot be stressed enough. The broadcast media hold a certain credibility with the majority of people. "I saw it on television" is enough proof for many people. This is both good and bad. It adds a certain value to those things we say in our video scriptwriting, but it requires us to work extra hard to ensure something's accuracy. The structure of a news story for broadcast usually differs from that of the print media. The first thing in the broadcast story is the "WHAT". This will attract the listener's attention and alert them to what is about to follow: the details. Since viewers cannot absorb all the facts in the first line, they must be given them in a form that will enhance understanding. Instead of What happened to whom, when and where with a why thrown in and then explaining it in the rest of the story, broadcast style is more like "What happened," "It happened where and when," "This is why it happened," and we'll put in the how if we have it.

## **The Lead**

The lead sentence should have enough information about What happened to arouse the listener's interest, without passing on too much information for the listener to comprehend. A lead sentence should be 20 words or fewer and contain as much information as possible without overloading the listener. A good idea is to begin the sentence with one or two words that are NOT the essential information in the story. Don't begin with essential numbers for the same reason. Much of the time, the viewers' minds aren't geared for the story and it takes a word or two for them to be fully alerted to receive the essential information. Usually, a lead can be made much better by changing it around a little. EXAMPLE: "130-THOUSAND SOLDIERS COULD BE CUT FROM THE ARMY IN THE NEAR FUTURE, IT WAS ANNOUNCED TODAY." This would be more assured of the listener's understanding if it were worded "THE ARMY ANNOUNCED TODAY ANTICIPATED MANPOWER CUTS OF 130-THOUSAND IN THE NEAR FUTURE."

## **The Body**

After the lead, the story must have a logical development. This is the body. It's, quite simply, telling the rest of the story in an orderly fashion, flowing smoothly to an end. Of course, the most important fact will come next and the next most important fact next, and so on. This is important in broadcast writing because air time is limited and valuable. Typically, the same story will be divulged in both the print and broadcast media. It isn't at all uncommon for the broadcast version to be only one tenth as long as the print version.

**Tense.** The natural tense for broadcast copy is the PRESENT TENSE, since most news reporting is of current, or at least, very recent news. However, every story doesn't have to sound as though it happened in the last minute. As a matter of fact, many events that the audience knows are in the past must be reported in the past tense. A good example of this would be in reporting sports scores. It's acceptable to headline something in the present tense to entice the audience to come back after a break, such as "Ohio State upsets Notre Dame...that, and the rest of the sports scores right after this." But the fact that they are final scores makes them past tense and they should be reported as such.

**Voice.** Broadcast copy should be in the active voice. The active voice has the subject of the sentence doing the action rather than the subject receiving the action. It's not only quicker, it's more conversational and carries more impact.



EXAMPLE:

Passive: THE EVIDENCE WAS GATHERED BY THE POLICE DEPARTMENT.

Active: THE POLICE DEPARTMENT GATHERED THE EVIDENCE.

**Write for the ear.** In keeping your copy conversational you'll be writing for the ear. Your video will enhance the audio, but the audio must be able to stand alone. It is for this reason that we refer to broadcast writing rather than just television writing. Remember, blind people listen to television and much of the time, sighted people listen to television while they're doing other things. Use everyday language. Write as people speak. Use contractions.

EXAMPLE:

Bad: WHEN QUERIED, IT WAS INDICATED BY THE POLICE CHIEF THAT AN ARREST WAS IMMINENT.

Good: WHEN ASKED, THE POLICE CHIEF SAID AN ARREST WAS IMMINENT.

**Sentence length.** Keep sentences short. They're easier for the newscaster to read and easier for the audience to understand. Remember, the lead should be 20 words or less and the rest of the sentences should be 25 words or less. Even though they can be 25 words long, sentences other than the lead should only average 17 words. They should vary in length to avoid a pattern effect. For spot announcements, the maximum sentence length should be 17 words. Shorter sentences give a feeling of action and urgency, but it's also easy to sound choppy if you're not careful to vary the sentence length within the word limit.

EXAMPLE:

Since they were not forwarded for a final vote, they can be resurrected only by a two-thirds vote of the house or by being added to bills under consideration later in house-senate conference committees, in which conferees try to reach agreements on bills that have passed the house and senate but in different forms.

This example is a sentence that was taken directly from a daily newspaper in a major American city. It illustrates the need to shorten sentences for broadcast copy. If you can go over it again, you can understand it, but try to read it aloud and make yourself understood. By dividing this

56 word sentence into four sentences of 14, 9, 15 and 19 words, we make it much clearer.

THE BILLS WEREN'T FORWARDED FOR A FINAL VOTE, BUT THEY CAN STILL BE RESURRECTED. ONE METHOD IS TWO-THIRDS VOTE BY THE HOUSE. ANOTHER IS BY ADDING THEM TO BILLS UNDER CONSIDERATION LATER IN HOUSE-SENATE CONFERENCE COMMITTEES. THESE COMMITTEES TRY TO REACH AGREEMENT ON BILLS THAT HAVE PASSED THE HOUSE AND SENATE, BUT IN DIFFERENT FORMS.

**Quotations and attribution.** It takes a little subtlety on the part of the broadcast writer when it comes to quotations and attribution. In the printed format, it takes nothing more than putting something in quotation marks. However, the listening audience can't see quotation marks. This can be overcome with the use of phrases like, "he said" with a slight pause before the quoted words or a faint change of tone. This will leave no doubt in the mind of the listener that he is hearing the exact words of the original speaker.

EXAMPLE:

THE CHIEF PETTY OFFICER WAS ASKED FOR HIS OPINION, AND HE SAID,...."I THINK SHE'S THE FINEST SHIP AFLOAT."

When it is absolutely necessary to remove all chance of doubt from the listener's mind, you can use "QUOTE" and "END QUOTE." However, this is disconcerting and certainly unconversational and you should avoid it when you can. If you're quoting someone and it's necessary to use a long quote, don't worry about rules for sentence length. Avoid long quotes whenever possible for obvious reasons. When you have to link the speaker with the quote, use conversational phrases.

EXAMPLE:

THE CHIEF ADDED....

or

HE CONTINUED BY SAYING...

It's usually a good idea to identify your source as quickly as possible. We don't want the listener/viewer to miss any of the important information because he's trying to figure out who is being quoted.

**Credits.** When quoting source material, since we can't use footnotes, we need to give oral attribution to both the source and its author, and it should be done in the first reference. Then in subsequent references we can attribute either the source or the author.

EXAMPLE:

IN THE "NINTH NEW COLLEGIATE DICTIONARY", MERRIAM  
WEBSTER PUT THE ACCENT ON THE FIRST SYLLABLE IN THE  
NOUN, "ATTRIBUTE." WHEN IT'S A TRANSITIVE VERB,  
HOWEVER, THE ACCENT IS PUT ON THE SECOND SYLLABLE.

Whenever a production is going to require a lot of attribution, it can be done all at once in the form of credits at the end. It can be done with a crawl by the character generator as well as by an announcer. It wouldn't hurt to include the credit in the copy since the video can be missed by anyone in the audience who is just listening. Of course, known facts need not always be credited. EXAMPLE:

IT'S TIME FOR ALL OF US TO REMIND OURSELVES TO,  
"ASK NOT WHAT YOUR COUNTRY CAN DO FOR YOU; ASK WHAT  
YOU CAN DO FOR YOUR COUNTRY."

As a broadcast writer, you must exercise careful judgment in determining whether such material is sufficiently original or identifiable with its author or source as to not require credit.

## **Numbers**

**From one to nine.** Write out: ONE, TWO, THREE, etc., unless they are being used for sports scores, times, dates or telephone numbers.

**From 10 to 999.** Use numerals: 10, 20, 30, 128, 925, etc.

**More than 999.** Both of the preceding styles apply with one slight addition. Substitute for the zeroes, words that mean what those zeroes represent, such as: ONE-HUNDRED, 15-HUNDRED, THREE-THOUSAND or 71-BILLION, etc.

**Dates.** JANUARY 1ST, JUNE 29TH, JULY 4TH, etc.

**Years.** Four digit numerals such as 1980 or 1995.

**Money.** 10-THOUSAND DOLLARS, TWO-MILLION YEN, 29-D-MARK.

**Fractions.** TWO-THIRDS, ONE-FOURTH, 17-THIRTY SECONDS.

**Percentages.** FIVE PER CENT, 22 PER CENT.

**Telephone numbers.** 542-4014 or EXTENSION 4-0-1-4 (for emphasis)

**Addresses.** ONE WEST EAGER STREET, 65505 NORTH 69TH AVENUE.

**Building numbers.** BUILDING ONE; BUILDING 400; etc.

**Ages.** THREE-WEEK-OLD BABY, 21-YEAR-OLD PRIVATE.

**Time.** 9:00 THIS MORNING or NINE A-M.

**Decimals.** 15-POINT-FIVE or FIVE-POINT-TWO.

**Roman numerals.** LOUIS THE 16TH, POPE JOHN PAUL THE SECOND.

**Ratings.** NUMBER SIX ON THE CHART, RANKED 26TH BY THE AP WRITERS.

**Scores.** 7 TO 3, 19 TO 12, 35 TO NOTHING.

**License.** B-R 549

**Military units.** SECOND BATTALION, 82ND AIRBORNE, SEVENTH ARMY. (Written as spoken)

**Equipment designations.** M-16 RIFLE, C-FIVE-A "GALAXY", C-ONE-30 "HERCULES"

## **Punctuation**

**The period.** As in any writing, the period indicates the end of a sentence or thought. More periods are used in broadcast writing because broadcast news sentences are shorter and more conversational.

**The comma.** A comma indicates a pause shorter than that of a period. Geographical names and most items in dates and addresses are also set off by commas.

EXAMPLE:

WE MOVED FROM FORT BRAGG, NORTH CAROLINA, ON JUNE 29TH,  
1985.

**The dash.** Use the dash to set off appositives and other parenthetical expressions.

EXAMPLE:

NATO -- THE NORTH ATLANTIC TREATY ORGANIZATION -- IS  
PRIMARILY RESPONSIBLE FOR....

**The hyphen.** Use the hyphen to help announcers in phrasing difficult words and to instruct them to pronounce individual elements distinctly.

EXAMPLE:

RE-ADJUST, RE-EVALUATE, W-A-B-C, F-B-I, U-S, A-M

DO NOT hyphenate or divide a word at the end of a line. Spell out the entire word OR move it to the next line.

**The dots.** Occasionally, you can use a series of three dots to indicate a pause longer than that of a comma. The series of three dots can be used for dramatic effect:

EXAMPLE:

THE JURY FOREMAN ANNOUNCED IN A CLEAR FIRM VOICE...  
"INNOCENT!"

**The quotation marks.** In addition to their normal use for indicating quotes, the quotation marks can also be used to set off nicknames, titles of books and plays, etc.

EXAMPLE:

THE ONE-HUNDRED FIRST AIRBORNE DIVISION -- BETTER KNOWN  
AS THE "SCREAMING EAGLES" -- MAKES ITS HOME AT FORT...

**Parentheses.** In broadcast copy, material in parentheses is information for the announcer, and normally not meant to be read aloud. It includes notes to the announcer such as pronunciation guides, a date, reading rates, etc.

EXAMPLE:

COLONEL PAYKEN (PAY-KEN) ARRIVES ON SUNDAY (MAY 21ST).

## Speaking Of Words

Remember, anyone can turn on a radio or television set. Choose words that everyone will understand, the announcer as well as the listener. Don't expect things of your audience. Make your copy clear and understandable.

**Contractions.** In day-to-day conversations, contractions are used liberally. "It's" instead of "it is," "they're" instead of "they are" will make your copy more conversational. A couple of exceptions to this are the "it will" contraction, "it'll," and "they will," "they'll," which are awkward to the ear.

**Pronouns.** There is a danger in using personal pronouns in broadcast copy. You must be sure your audience knows who you're talking about whenever you use "he," "she" or "they." The ear can't go back and pick-up the identification.

**Alliterations.** When you compose a sentence consisting of several words beginning with the same vowels or consonants, you have alliterations and the announcer has a problem.

### EXAMPLE:

THE WESTERLY WINDS WILL WHIP WRATH WITHIN WINDSOR...

or

THE DEVASTATED DAM DUMPED DRUDGE AND DIRT ON DES MOINES

**Sibilant.** Too many "s" or "sh" sounds tend to create a hissing sound when read aloud.

### EXAMPLE:

THE SIXTH SICK SHIEK'S SIXTH SHEEP'S SICK

And of course, you should always be aware of how difficult your copy will be to read aloud. Try it yourself if you have any doubt. This can be a second reason for reading your copy aloud in addition to double checking it for time. We'll discuss how to time your copy later.

**Homonyms.** Watch out for homonyms, words which sound alike but have different meanings. The listener can't hear the difference between "won" and "one," "bear" and "bare."

**Here and there.** Since your listeners could be anywhere, "here" and "there" can mean something different to each of them and change the meaning of your copy. These words can be avoided simply by calling

"here" or "there" by its name. If "here" is Fort Knox, say "FORT KNOX."

**Libelous words.** A libelous word would be any word that, if used improperly in your story, could lead to libel. Be very careful with words like: atheist, fascist, seducer, bigamist, rapist, murderer, illegitimate, deadbeat, addict, etc. Be especially careful with the word "for." Saying someone has been arrested "for murder" implies guilt. Instead say something like "arrested on a charge of murder" or "arrested in connection with the murder of..." Keep in mind also that until someone is convicted of a crime, they are only a "suspect" or the "accused" and their act is "alleged."

**Not, "not."** Avoid the use of the word "not" in your copy. "Not" can easily be dropped inadvertently and leave the listener wondering if he heard "not" or not.

EXAMPLE:

<u>Use</u>	<u>Avoid</u>
DISHONEST	NOT HONEST
INNOCENT	NOT GUILTY
FORGOT	DID NOT REMEMBER
UNABLE	NOT ABLE

**Other meaningless words.** Avoid meaningless words like "latter", "former" and "respectively" when referring to persons, places or things already mentioned. Again, listeners can't refer back. Likewise, avoid transitional phrases within your stories such as "meanwhile," "meantime," "incidentally." They're crutches. While each thought, phrase or paragraph should flow to the next, it should be done with skillful organization, not throwaway transitional words.

Steer clear of flowery phrases and trite expressions that take up time and space and add nothing. Avoid slang, vulgarisms and dialect in news writing.

Always translate military jargon, technical, legal and foreign terms into simple language.

EXAMPLE:

<u>Use</u>	<u>Avoid</u>
ASSIGNED	DETAILED
BEFORE	PRIOR TO
ENLISTMENT	HITCH
IF	IN THE EVENT OF
SAID	CLAIMED

**Good taste.** What can we say about good taste? It's relative. It's very easy to be misunderstood, and even when your meaning is quite clear, there's a chance that someone will feel it's in bad taste. You MUST, therefore, take all precautions to be sure your words, phrases and manner of presenting information will not embarrass your command, your service, or the United States Government.

### **Handling Titles and Names**

Don't lead off a broadcast story with a person's name if you can avoid it. In the case of names and titles being used together, precede the name with the title. It should be, "SPECIAL AGENT ELLIOTT NESS," not "ELLIOTT NESS, SPECIAL AGENT." This alerts your listener that a name is coming up and gives them a better chance to comprehend your story.

#### Official titles

Refer to federal office holders by title or as "mister" or "ms." That is SENATOR JONES or MISTER JONES...CONGRESSMAN SMITH or MISTER SMITH...CONGRESSWOMAN BROWN or MS BROWN...

**Difficult names.** Whenever a difficult name isn't essential, use the person's title, such as "THE FOREIGN MINISTER OF SWEDEN..."

**Initials.** It's best to omit initials in a person's name unless it is a well-known part of the person's name such as HOWARD K. SMITH or MICHAEL J. FOX or F. LEE BAILEY. The other exception is when the nature of the story requires further clarification, such as births or deaths.

**Phonetic spelling.** If there's any way for an announcer to mispronounce a difficult or unusual name, assume he'll do it. So give him all the help you can. Write the phonetic spelling in parentheses, and place it immediately behind the troublesome word. Be sure to underline the phonetic syllable that is to be accented or stressed.



EXAMPLE:

SERGEANT KOLLMAN (COAL-MAN) ENTERED...

MUNICH (MEW-NICK), GERMANY IS THE CAPITOL OF....

Make sure the phonetic spelling appears on the same line as the word it represents.

When abbreviations are used, they are intended to be read as abbreviations. The use of well-known abbreviations is permissible, such as...Y-M-C-A, F-B-I, U-S, A-M, or P-M. You may also use MR., MS., and DR. "ST." may be used instead of "SAINT" as in ST. LOUIS.

Do not abbreviate military ranks or installation names. Use CAPTAIN CARLISLE (not CPT.), STAFF SERGEANT BAILEY (not SSG or SSGT.). Use FORT (not FT.) KNOX. Use NAVAL AIR STATION (not NAS). UNITED STATES or U-S AIR FORCE (not USAF).

### **Other Considerations**

**Abbreviations.** A good rule to remember on the use of abbreviations in broadcast copy is...WHEN IN DOUBT, WRITE IT OUT. Hours and hours of extra time spent in writing things out isn't worth trading for one moment's embarrassment on the air. Consider as well, the additional chance of misunderstanding on the part of the listener.

Never abbreviate names of states, cities, countries, political parties (except G-O-P), days of the week, months, titles of officials and address identification such as street, avenue, drive or boulevard. Never start a sentence with an abbreviation, word, or number. WHEN IN DOUBT, WRITE IT OUT.

**Acronyms.** When using an unfamiliar abbreviation or acronym that will be pronounced as a word, be sure to spell it out in the first usage.

EXAMPLE:

"THE DEFENSE INFORMATION SCHOOL, COMMONLY CALLED DINFOS.."

"CHAMPUS - THE CIVILIAN HEALTH AND MEDICAL PROGRAM FOR THE  
UNIFORMED SERVICES - HELPS SERVICEMEN AND THEIR FAMILIES."

**All-CAPS or Upper/lower case.** Do you type broadcast copy in all-caps or upper and lowercase letters? Some newsrooms favor an all-caps format for consistency with copy coming over teletypes. Studies, however, show that copy typed in upper and lowercase letters is easier to read. One thing to consider when using upper and lowercase is the chance of failure to capitalize, which could confuse an announcer and cause him to stumble.

**Timing your copy.** The total line count of a broadcast news release is the most common measure of the length or time. In television scripts, the storyline, or audio, shares the page with the video. Therefore, with only half the page for the story content, the typewriter margins are set for an average of 35 characters or spaces per line. As a result, 14 to 16 lines of television copy will average 30 seconds, or two seconds per line.

**Total word count.** Though not the preferred method, the length or time of a broadcast news release can also be measured by total word count. Announcers read at varying speeds, but the average is two-and-a-half words per second. This would mean approximately 150 words for a 60-second story.

**Numbering pages.** Whenever your broadcast copy is more than one page, pages are numbered consecutively: 1 of \_\_, 2 of \_\_, 3 of \_\_. If your script is 10 pages long, the first page would be numbered 1 of 10, and the last page would be numbered 10 of 10. Page numbers are typed in the upper right hand corner of the page. Page numbers are extremely important in broadcast copy. Imagine an announcer on his way to an air shift, exactly on time who drops his copy and gets the pages mixed up. There won't be enough time to sort them out if they don't have page numbers.

**The four-unit heading.** This consists of a slugline, date, length of copy and type of release. The slugline serves as a little headline of the story. The date is the date the release was prepared. The copy length tells in seconds approximately how long it will take to read the story. There are two types of releases: the immediate release for hard news items and the like, and the general release for soft news, features, spots or any other material that doesn't have the immediacy of hard news.

EXAMPLE:

OUTDOOR RECREATION

APRIL 1, 19XX

(30 SECONDS)

FOR GENERAL RELEASE

In place of the type of release, you can have a DO NOT USE AFTER line with time and date. This is for timely material, usually about an event

that will run for a limited time. It gives the broadcaster a cut-off date or time to discontinue airing the release. You can also have a HOLD FOR RELEASE UNTIL line for advance releases. This is a good tool for providing material in advance, even though it shouldn't be aired until a certain time. It allows others to plan and schedule without putting the material out too soon.

**Video-change spacing.** In television copy, the rule is double spacing. When a video change is to occur in a television script, we then triple space. This alerts the announcer that there is a video change taking place. It may be returning from something else to the announcer on camera where more eye contact is required. The announcer shouldn't be seen looking off camera, and if for some reason he needs to look elsewhere, such as to a monitor for an on-cue point, the script will alert him as to when he won't be on camera.

**On-cue.** When reading to a videotape in a television script, announcers need a way to prevent coming out way ahead of the tape, or being too slow and thus behind the tape. The method used to do this is "ON-CUE." At selected points in the script, the writer builds in places for the announcer to pause, look at the studio monitor and wait for a particular point at which to restart. The number of times this is done in a script depends on the length of the script. The longer the script, the more times the announcer should pause. This is one way to provide for the varying speeds at which different announcers read.

**The end or # # #.** The number symbols, # # #, indicate the end of your broadcast release. Sometimes called "Dunphys," they should be centered under your manuscript column. You should have the word "more" in that same position at the end of each page to indicate that there is more copy on another page.

### **Editing Broadcast Copy**

Absolutely clean copy -free of mistakes -is the rule for copy designed for outside release to television stations. Sloppy copy is a distraction to the broadcaster and it says something about you, your leadership and your unit that no one wants said. For in-house productions, edit marks may be used sparingly, but only those edit marks that are easily understood. DO NOT USE PRINT MEDIA COPY EDIT MARKS.

When inserting a period, comma, question mark, exclamation point, apostrophe, etc., just insert the mark where it should go. For other corrections, use one of the following broadcast editing methods:



are in the active voice and paint word pictures.

Features need logical development to be convincing. The lead sentence should grab the listener's attention. A sequential arrangement of facts brings the story to a logical conclusion.

At the end, a telling point illustrates the central idea or the informational objective of the story. Often, the telling point refers to the lead by restating the same idea.

Good features don't just happen...they're created through skillful writing.

### **Spot Announcements**

Americans grow up with commercial messages and spot announcements. In contrast to features that may be used only once, commercials or spots are usually aired over and over again.

Department of Defense public affairs members do not write commercials. We write spots or spot announcements. Understandably, there is a similarity, since commercial messages are often called spots.

We think of the civilian media spot or commercial as something that sells a product. The spot announcement, as it applies to DOD public affairs, can do even more. It can "sell" the viewer on an organization, activity or attitude.

**Types of spots.** There are two forms of spot writing: SELLING and INFORMATIONAL.

The SELLING spot informs the viewer, then tells him to **do something**. The selling spot has three steps: ATTENTION, APPEAL, and ACTION.

The INFORMATIONAL or information spot simply **informs**. The information spot uses only the ATTENTION and APPEAL steps. It does not specifically tell the audience what to do (action, etc.). It simply informs.

None of the sentences in a selling spot should be over 17- words and the action step should not exceed six words.



**AFTV**  
INFORMATION  
ENTERTAINMENT

NAME PVT SAM S. SMITH  
TEAM B  
EXERCISE THREE  
DATE 12 MAR 91 PAGE 1 OF 1

---

VIDEO

AUDIO

---

SWINE FLU SHOT  
(12 SECONDS)

MARCH 12, 1991

FOR IMMEDIATE RELEASE

STUDIO LEAD IN

MARION COUNTY'S SWINE FLU VACCINATION  
PROGRAM GOT A SHOT IN THE ARM TODAY.  
THIS SEASON'S FIRST SUPPLY OF THE NEW  
VACCINE WAS MADE AVAILABLE TO THE  
PUBLIC. WE GET THE DETAILS NOW FROM  
ARMY PRIVATE SAM SMITH.

(Example of EJ Script for a Studio Lead-In)



**AFTV**  
INFORMATION  
ENTERTAINMENT

NAME SPC ROD CARLISLE  
TEAM C  
EXERCISE TWO  
DATE 12 MAR 91 PAGE 1 OF 2

---

**VIDEO**

**AUDIO**

---

FORT HARRISON LIBRARY  
(90 SECONDS)

MARCH 12, 1991

FOR GENERAL RELEASE

M/S LIBRARIAN AT DESK  
(056 - 076)

ROD CARLISLE:

(WHISPERING) IF YOU EVER FELT THAT  
THE LIBRARY WAS A QUIET PLACE WHERE  
YOU WOULDN'T EVER ENCOUNTER NOISE,  
WE HAVE A SURPRISE FOR YOU.

L/S WORKERS INSTALLING PANELLING  
(098 - 123)

(NORMAL VOICE) THE FORT HARRISON  
LIBRARY IS EXACTLY THE OPPOSITE OF  
THAT RIGHT NOW.

M/S CARPENTER SAWING PANEL  
(133 - 145)

IN AN ATMOSPHERE THAT'S NORMALLY AS  
HUSHED AS A LIBRARY THE SLIGHTEST OF  
SOUNDS CAN BE DEAFENING. LOUD NOISES  
ARE EVEN WORSE.

C/U SAW BLADE IN PANEL  
(189 - 193)

HARRY JONES, CONSTRUCTION FOREMAN, IS  
EXPECTING THE WORK TO TAKE ANOTHER  
TWO DAYS. HE SAYS THE IMPROVEMENT  
WILL BE IN MORE THAN JUST APPEARANCE.

(MORE)

(Example of TV News Script for EJ)



**AFTV**  
INFORMATION  
ENTERTAINMENT

NAME SPC ROD CARLISLE  
TEAM C  
EXERCISE TWO  
DATE 12 MAR 91 PAGE 2 OF 2

---

VIDEO

AUDIO

---

ROD CARLISLE CONT'D:

M/S CARPENTER FITTING PANEL

(204 - 213)

AS EACH PANEL IS PUT INTO PLACE...

C/U CARPENTER'S HANDS ON EDGE

(227 - 234)

IT'S OVERLAPPED ON A PIECE OF...

L/S ENTIRE WALL BEING FITTED

(254 - 263)

FOAM BACKING THAT INSULATES, NOT ONLY  
TEMPERATURE, BUT SOUND AS WELL. THAT  
TAKES CARE OF OUTSIDE NOISE.

M/S PANELLED WALL THROUGH BOOK SHELF

(274 - 282)

HOWEVER, WHEN YOU COME TO THE LIBRARY  
IN THE FUTURE, A CERTAIN PART OF THE  
PAST WILL ALWAYS REMAIN.

C/U OPEN BOOK ON TABLE

(286 - 298)

WHEN YOU SIT DOWN TO ENJOY ALL THE  
WONDERFUL VOLUMES YOUR LIBRARY HAS TO  
OFFER, YOU'LL BE EXPECTED TO REMAIN  
QUIET.

STAND UP

(WHISPERING) WHISPERING FOR A-F-T-V  
NEWS, I'M SPECIALIST ROD CARLISLE.

# # #

(Example of TV News Script - Cont'd)





**AFTV**  
**INFORMATION**  
**ENTERTAINMENT**

NAME SGT KARL DAVIS  
 TEAM D  
 EXERCISE THREE  
 DATE 12 MAR 91 PAGE 1 OF 2

---

**VIDEO** **AUDIO**

---

TRAFFIC JAM AT FORT HARRISON  
 (90 SECONDS)

MARCH 12, 1991

FOR GENERAL RELEASE

KARL DAVIS:

L/S TRAFFIC JAM ON POST ROAD  
 (007 - 015)

TRAFFIC HAS BEEN SNARLED FOR THE LAST  
 THREE MORNINGS ON POST ROAD.

M/S PIPELINE CONSTRUCTION  
 (019 - 022)

IT'S PART OF A PROGRAM TO UPGRADE THE  
 NATURAL GAS PIPELINES SUPPLYING THE  
 POWER PLANT.

C/U OLD AND NEW PIPES  
 (025 - 034)

EIGHT-INCH PIPE IS BEING REPLACED  
 WITH 14-INCH PIPE.

C/U JON SCHAIFER  
 (013 - 019) (A-ROLL)

WE ASKED POST ENGINEER JON SCHAIFER  
 HOW LONG THE CONSTRUCTION WILL TAKE.

W/S CONSTRUCTION SITE  
 (045 - 054)  
 M/S FLAGMAN  
 (061 - 069)  
 M/S PIPE LAYING OPERATIONS  
 (073 - 076)

ACTUALITY (28 SECONDS)  
 IN CUE: "WE ESTIMATE THAT THE...  
 OUT CUE: ...AHEAD OF SCHEDULE."

(MORE)

(Example of TV News Script with Actuality)



**AFTV**  
INFORMATION  
ENTERTAINMENT

NAME SGT KARL DAVIS  
TEAM D  
EXERCISE THREE  
DATE 12 MAR 91 PAGE 2 OF 2

---

VIDEO

AUDIO

---

KARL DAVIS CONT'D:

L/S CONSTRUCTION SITE  
(085 - 087)

IMPROVED HEATING AND AIR CONDITIONING  
COSTS IN MANY WAYS.

STAND UP

AND THE TRAFFIC PROBLEMS ON POST ROAD  
IS ONE WAY YOU'LL CONTINUE TO PAY.  
FOR A-F-T-V NEWS, I'M ARMY SERGEANT  
KARL DAVIS.

# # #

(Cont'd Example of TV News Script with Actuality)



**AFTV**  
INFORMATION  
ENTERTAINMENT

NAME SGT EDDIE HORNER  
TEAM E  
EXERCISE SEVEN  
DATE 12 MAR 91 PAGE 1 OF 2

**VIDEO**

**AUDIO**

LIBRARY SPOT  
(30 SECONDS)

MARCH 12, 1991

FOR GENERAL RELEASE

ANNOUNCER:

W/S FAST Z/I TO LIBRARY DOOR

YOUR LIBRARY IS THE SCENE OF ACTIVITY

M/S FAST Z/I TO BOOKSHELF

IT'S NOT JUST A PLACE TO STORE BOOKS.

FRAME COMPRESSION BOOK OUT TO FILL

INSIDE THESE PAGES ARE MINIATURE  
WORLDS

SLIDE #4593 SHIP IN LAGOON

WORLDS OF ROMANTIC VOYAGES...

DIGITAL FLIP TO NEW SLIDE #4973

FLIGHTS OF FANCY...

LOSE SLIDE TO STAND UP

JUST ABOUT ANYTHING YOUR HEART  
DESIRES AND IT'S SO EASY TO PICK UP  
YOUR VERY OWN LIBRARY

ECU LIBRARY CARD Z/O TO FORM

CARD. ALL YOU  
NEED DO IS FILL OUT A SIMPLE FORM,  
WITH YOUR UNIT NAME AND BUSINESS  
PHONE.

(MORE)

(Example of TV Spot Script for EJ)



**AFTV**  
INFORMATION  
ENTERTAINMENT

NAME	SGT EDDIE HORNER
TEAM	E
EXERCISE	SEVEN
DATE	12 MAR 91
PAGE	2 OF 2

---

VIDEO

AUDIO

---

W/S MAN AT BOOKSHELF

C/U HAND ON BOOK

CG: LIBRARY PHONE NUMBER

ANNOUNCER CONT'D:

THEN YOU'RE IN BUSINESS. YOU HAVE

ACCESS TO ALL THE WONDERFUL

BOOKS THAT CAN OPEN NEW

WORLDS OF  
EXCITEMENT. IT'S ALL AT THE LIBRARY.

# # #

(Example of TV -Spot Script for EJ)

## **ANNOUNCING**

The announcing in TV news inserts is done by a reporter. Reporters are the heart of the news gathering system. Without them, there would be no news. In most cases, they go out, gather the facts, do the initial writing and editing and process it all into a news story.

While there are few differences between military and civilian broadcasts when it comes to television, one of the most obvious is in the appearance of the reporter in the news insert. In civilian television reporters are seen doing their work in the field or in the studio. The audience comes to know them and respect them. Most reporters gain a celebrity status. They usually have some title such as investigative reporter, or economics reporter, field reporter, general assignments reporter, and so on.

The military reporter, on the other hand, usually does all the reporting, and seldom appears in his work. We are not in the position for the purpose of marketing ourselves or becoming celebrities. A certain amount of recognition is unavoidable in the course of getting the job done, and it will even lend credibility to our product. You will find a level of cooperation present almost everywhere that few other military people experience. It's all right to smell the perfume as long as you don't drink any of it. Remember what you are there for, and that your most valuable asset is the ability to communicate information and ideas clearly for the purpose of command or public information. Use the recognition and cooperation to get the job done and create a better product.

In this lesson, we'll talk about what reporters do with ENG technology, and how they do it. Although technology doesn't do the work for the reporter, it does have a lot to do with it. Good solid reporting still begins with Who, What, When, Where, Why and How. Those elements, processed with accuracy, brevity and clarity, are still the necessary ingredients of good news reporting. Beyond that, the ability to find the right word or turn a phrase at just the right time to make the report interesting, informative and illuminating, will make the news report, as well as the reporter, stand out.

There are two basic types of news reports you will generally be dealing with. They are the spot news event and the news feature. The techniques you employ to cover these two types of stories will be similar, but with one important difference. That difference is in how much time you have to prepare for the story. The news feature can be planned well in advance, allowing the reporter time to think about and plan the coverage. An example of the news feature would be the flu shot program or the remodeling of a facility where it is news, but planned. The spot news event is

a breaking event, usually fast-moving and spontaneous. It seldom allows for any planning except in the most general sense. Examples of spot news would be fires, accidents, explosions, natural disasters, hijackings, shootings and other bad news events.

The only planning for spot news events would be in the form of some kind of disaster plan. The best way to begin to formulate a disaster plan is to say, "What if.." and then follow it with every contingency you can think of. Although you'll never be able to anticipate every possibility, you will be better prepared for many spot news events.

### **The Spot News Event**

Coverage of a spot news event, a breaking story, presents a number of challenges. There will be two basic situations you'll be in when the story breaks. One will be when you're around your unit or station doing other things. The other will be when you're out covering something else. If it's the first, grab the equipment, find out as much about the situation as possible in a minute or two and get out to the site of the event. If it's the second situation, the timing usually means you'll have to either discontinue or rapidly conclude the story you're working on and move to the new location. Here is where planning of a general nature will come into effect. Will it be your habit to take double the batteries and tapes out on each shoot, or will you not have enough with you to do another story?

Experienced reporters will attest to the fact that this is where you'll have the most difficulty in ENG. The ability to change gears right in the middle of the story and go to something completely unrelated and start all over is perhaps one of the most difficult things to achieve. It can even be a bit dangerous in certain situations such as events where there is confusion and chaos. People get hurt in training accidents even when training is all they have to concern themselves with. Coming from an unrelated situation and different mind-set will add to any danger that is present.

**Train for safety.** Since television news field reporting can take you anywhere it is necessary to stress safety. Air crews are constantly reminded that safety is paramount. They are alert to dangerous situations and try to stay out of them. They follow preflight checks and flight rules scrupulously. You should pay as much attention to safety as the air crew.

ENG equipment is bulky, and you'll often have to take it into dangerous areas. Use common sense, sharpen your instincts, and protect yourself and the other members of your crew from danger. It would be silly to drive

so fast to a news event that you have an accident on the way. Likewise, around a construction site, you should stay clear of heavy equipment in operation. Stay well back from exposed electrical power lines. Don't lean far out of a tenth floor window to get that high-angle shot. Don't set up in the middle of a superhighway for that great into-frame-out-of-frame sequence. Don't set up your tripod on loose ground. When carrying the camera, be careful of where you step and always be aware of what is beside and behind you. Above all, don't become fixed in the viewfinder so much that you are unaware of danger around you. Since the viewfinder is a miniature television screen, don't get the feeling that since you're seeing the action on television, it's the same as sitting in your living room watching a war movie. **You're still in the thick of the action.**

**Teamwork.** The relationship of the reporter to the crew is critical. It must be a positive relationship if the team is to succeed. In a business where personalities and egos sometimes get swelled out of proportion, it is imperative that everyone be willing to accept the professionalism of others, particularly in military organizations where duty assignments require people to work in the same place without consideration of personalities. Personnel administration has enough in the way of limitations without adding problems like the inability of two large egos to work together professionally.

It may not be necessary for crew members to like each other personally, but they must get along well professionally, and not allow personal differences to get in the way of the mission. Perhaps the most important element to being able to work together is to communicate. If everyone is willing to talk out differences with an open mind, you will come to an understanding, sooner or later. Be polite to your fellow team members, and mean it. Develop the habit of using the words "please" and "thank you." A little courtesy goes a long way, both with your fellow workers and with the public.

Everyone should have a mutual respect for the equipment, and the problems the other crew members have in operating it. You can't detach yourself from the need to protect it and take proper care of it.

**Reporting the spot news event.** There are five general reporting problems that we must deal with in the spot news event.

- o Time constraints and deadlines
- o Fact gathering
- o Sources
- o Building the story
- o Clarity

**Time constraints and deadlines.** There are few assumptions that are acceptable, especially when you deal in facts. One of them, however, is assuming that you won't have enough time to get everything you need for your story. Don't hurry to the point of doing substandard work, but if you keep in the back of your mind the fact that you'll seldom have enough time, you'll be less likely to waste it. You may have deadlines or time pressures of another kind placed on you. Maybe the event occurs mid-afternoon and you need to get your report covered and filed before the evening news. Timing is everything. If it isn't on the news tonight, it'll be in the newspapers before the news tomorrow night and that will take all the immediacy out of your report.

As you race around to find out what you can, stick to the basic elements. You'll have a better chance of getting what you need than if you run around without any organization. Remember Sergeant Friday of *Dragnet*... "Just the facts, Ma'am!"

**Fact gathering.** You must capture the basic framework, the Who, What, When, Where, How and Why of the story as quickly as possible. These are always the basics you need in any story. The How and Why are not always as easy to obtain as the others, but they are also the two that you can find out more about later. Beware, however; they are also the two where people are most likely to speculate.

**Sources.** Be sure of your source. Very often when you are at an event, people will want to get on television and they will want to be interviewed. That will make it difficult for you to sift out what is factual and what is not. Here's a list of things for you to think about.

- o Who is in charge?
- o Who is the official source?
- o Who or where is the information coming from?
- o Is there anyone here whom I know is the authority?
- o Is there more than one side to this?
- o If so, who is the spokesman for each side?
- o Is what I hear the same as what I see?
- o Do I see something others don't?
- o Can, or should, I do something about that?
- o Does anyone here have a personal interest in this?
- o What can, or should, I do about that?
- o Is there more than meets the eye?
- o Will this event affect other important things?

When asking yourself these questions, you may not be able to come up with answers to all of them. The information you get will determine how many questions you'll be able to answer correctly. Some people may give you opinions based on limited knowledge they have at the moment. Some may try to give their versions for personal reasons. And remember, everyone isn't



a journalist, and some people speculate. The more you cover the better you'll get at sensing what are facts. The more you know about the military, the more you'll be able to distinguish truth from fiction in military events. You will have to rely on common sense, experience and gut feelings. Ask yourself: Does this make sense? Is it logical? Does it come from more than one source? Did you check with more than one source? Is this the best source? Does the source know first hand or second hand, or even less directly? If your source uses phrases like "I was told," or "I heard," perhaps you should seek out another primary source. Is it official, unofficial or rumor? We never report rumors, but we do check them out.

**Building the story.** You'll find the most precious commodity at a spot news event to be the time necessary to think things out. There will seldom be enough time, but you must take enough time to formulate your story properly. Determine the approach you are going to take with the story. Stay with the basics. Develop a sense for what is important and what is significant. It's up to you to build for your audience a clear, concise picture of the main elements of the event. Keep it straightforward and simple. Take it a step at a time. Develop and finish one element before going on to the next. Don't jump back and forth between important elements in the story. Keep the story organized and moving forward. Make your story a tight report of known facts and keep it in logical sequence.

After you have done a good job of building the story and giving your audience all the important facts in logical order, be sure to have a good solid ending. How you end the story can be the finishing touch, or the one effort that destroys all your other efforts. You may want to re-cap or summarize the facts you've reported. But be brief. Don't get carried away with your eloquence.

**Clarity.** There will be later chapters on writing and scripting, but it is logical to point out here that all the rules of simple, tight, easy-to-understand writing that apply to the writing of a script, also apply to anything you may conjure up or ad-lib on the spot. It's almost impossible to maintain proper wording and grammar if you start using a lot of compound and complex sentences. You wouldn't do it in the writing of a script. You shouldn't do it in what you put together in the field on a spot news report. Always try to:

- o Use declarative sentences.
- o Keep verbs in the same tense throughout the story.
- o Keep pronoun references clear.

When using big colorful words, you take a chance on conveying an incorrect meaning or creating a false impression. Sometimes the more simple

language is called for. It's better to speak below some of your audience and be understood by all than to speak above any of your audience and not be understood by some. Beware of speaking down to anyone though. Strive for that balance where your audience understands you and can relate to what you say.

### **The News Feature**

Unlike the spot news event, the hard news feature will probably allow you at least a little time to research the subject, to plan the coverage possibilities, and set up some aspect of the coverage in advance. On-camera interviews with people who make the news can be scheduled. You can outline the story and a tentative structure can be applied to it.

Proper research takes hard work. You'll get a jump on any story with library files and scripts on file of all of your past stories. If you have any sort of beat system, you should have file footage and facts concerning your beat. These may include newspaper and magazine article clippings, other background information, any notes you've made, lists of phone numbers and in short, anything regarding anyone or anything you may be called upon to cover. Of course, you'll have to have some sort of filing system that will allow you to lay your hands quickly on needed information.

Even if you're not a fountain of information on a given subject, you may have sources that can enlighten you about your topic. By contacting knowledgeable sources, you might quickly improve your chances of getting the right information, or at least bringing up to date what you have.

If you don't even have enough information to know what to find out, that in itself is a good question. "If you were me, what would you ask?" If research is important --and it is --what you do with the information is even more important. Use what you learn as a foundation. Think things through and try to imagine and question every possible aspect of the situation. Who is involved? What do you want to ask them? What is the mood of the story? What are some of the visual possibilities and opportunities? What about natural sound? What might be particularly difficult, dangerous, sensitive, or hard to understand? How can you really bring the story to life for your audience? When you get answers, think of what further questions they bring about. There is no substitute for research. The better you are informed, the more completely you can tell the story.

Those are just some of the questions you can ask about almost any situation or story. As you go through the mental exercise, other questions will come up. That's one of the advantages of the procedure. All the while, you'll be getting valuable insights and perspectives on the story, and that's the first step in producing a precise report that will make sense to your viewers.

When do you spend time on research? In spot news event coverage, the event is happening now and if you were to take time to research something, the event would be over and you would not have covered it. That's why you have contingency plans. In the news feature, there is more often time to spend on research. You may think that time is too precious to waste, but the truth is, you can't afford not to spend the time. It's the price of excellence and success. Having done your research, you begin to gather the facts in the field. Start looking for information that will help you answer the final questions you should be asking yourself. The most important questions are:

- o What do we really have here?
- o What is this story about?
- o What does this story mean?
- o What do we want to convey to the viewer?

These are simple questions. Try to come up with equally simple answers. Be aware that sometimes the most obvious answer may not be correct. Take a good look at your answers and try to find fault with them. Play the devil's advocate to yourself.

All this may be a lot of mental exercise, but it's worth it. You'll find that the rest of the job will be much easier. Now you're coming to the most interesting part of the job, putting together your field report and organizing all your facts into a story. Remember, a story has a beginning, a middle, and an end.

**Opening Segment.** As we said, your story must have a beginning, a middle and an end. Which is the most important part? Even the experts disagree. Everyone will agree, however, that all three parts are important. The best way to treat that question would be to feel that they are all too important to give any less than maximum effort. They are three distinct segments and each of them is important in its own way. It makes good sense to give each of them special attention.

The intent of the open or lead is to attract the viewers' attention. You must grab their interest and point them in the direction the story will take.

There are two types of leads: hard and soft. A soft lead is rather non-specific and generalized. It sort of flows into the story. A hard lead, on the other hand, is much more specific and direct. It zeros in on the most newsworthy element of the story.

Either way, the lead must stimulate the viewers to pay attention to the story. But it's not just a matter of getting their attention, it must be done in such a way as to be consistent with the rest of the story. Changing gears right after the lead will only serve to disorient or disappoint your audience when what you really want to do is focus their attention on your message.

**Including An Actuality.** If you are going to include an actuality in your report, be very careful in the wording of your questions. Remember, you have one goal, to get the word "straight from the horse's mouth," so to speak. You will use either the newsmaker or an eyewitness of the event. Either way, the interviewee will most likely be unaccustomed to being on camera or at least unfamiliar with what you need most from him. There are two hazards to avoid: the yes-or-no answer which is, of course, too short and the non-stop talker whose answer takes too long. Most people will fall into one of these categories if not handled correctly. It's the question and how it's asked that will assure your success or failure in avoiding these pitfalls.

Your interviewee will most likely lack announcing skills as well. He won't know how to talk to only one person when addressing a camera. Be the one person for him to talk to. Listen to his answers and look at him when he is answering your questions. Looking around or checking your notes while he is talking is both rude and distracting. He will probably think that you have tuned him out, and may even stop talking in the middle of his answer. You will also stand a much better chance of coming up with that obvious follow-up question that will clarify his answer.

**Control of time.** Since you're taping your actuality, re-ask a question if the answer is too long-winded. Reword your question so that the answer will be more along the lines you're looking for. But avoid things like, "In other words, you mean ....." This is bad for two reasons. You're putting words in the interviewee's mouth which may or may not be what he wants to say, and you might get a simple, "Yes." Another time-control measure is to keep your questions short and to the point. Let the interviewee tell the story. After all, that's the purpose of doing an interview in the first place. Interviewees can sometimes get off track or provide more detail than you need. Here's where you must take control. Although interrupting is normally rude, it may be necessary. There are acceptable ways to do it. Be gentle. A "Pardon me," or "Excuse me," never

hurts, but they can go along with a "Let's emphasize that point," or "Can we go back over that?" to let the subject in on what you're doing. Most people will understand if you handle it properly. You might be surprised at how your subject will respond to a well-coined phrase like "In the remaining few seconds," or "We have time for just a brief word." If they have ever watched television, chances are they've seen this done before.

Get in the habit of leaving a brief pause between questions and answers. It needn't be anything long, but you'll find that a little space will come in handy during editing. You will always be able to edit out any dead air.

**Reverse questions.** These are also called reporter cutaways. You will want to ask the questions again with the camera on you. The subject will understand with just a brief explanation. Be sure to do it in the presence of the interviewee and in the same spot for continuity in editing. Normally you won't use the questions in your finished piece, but be very careful to ask the questions with exactly the same wording so if you do need to use all or part of the footage, you'll be able to edit anywhere you want. This reverse angle footage can be useful in a number of ways. One would be to cut an answer short by switching to the video of you, with a slight pause beforehand, going into the next question.

You'll want some reverse angle video of your reactions to the subject's answers. Then if the subject looks off camera, or something else of a visual nature is distracting, you can just edit it out, without interrupting the audio that you want to keep.

**Get to the point.** If the opening segment grabs the viewer's attention and the close wraps it all up, then the middle is where you do the real telling of the story. Stick to the point. Remember? What does this story really mean? Don't be afraid to explore side issues, especially if they add to or shed light on the real story, but make sure you don't ramble around on a lot of issues that don't belong in the story. Don't forget the five W's and the H.

**Concluding The Story.** The closing of your story is at least as important as the opening. After an opening aimed squarely at the mark and a body that brings all out the facts and gives a clear, concise picture of the event, you need to tie it all together in a manner that will make sure the viewer gets all the information. Be sure that your close comes from the facts already in the story. A summary or recapitulation of the three or four main points of the story will ensure the viewer understands what has been presented.

Above all, remember that reporters are reporters and not editorial writers. Just as you would not insert conclusions that are not supported by fact, neither should you insert your own personal opinions, judgments or characterizations. Good field reporting requires all of the reporter's ability to tell the story in a clear, concise, logical manner. The hard news feature requires careful planning, organization and intense focus on the story's main point. The spot news event by its nature doesn't allow the specific event planning of the feature, but planning in the generic sense should still be there. And, of course, tight organization and intense focus are still a requirement. Because time will not allow you to tell everything there is to know about a story or event, it's up to you to decide the main point of the story and convey it to your audience.

## **INTERVIEWING**

This is where it's extremely difficult to do the whole job by yourself. Interviewing in the field is best done by two. One, the reporter, and two, someone to shoot the video. It can be done by one person, but if at all possible, there should be at least two members in the crew. This lesson is going to address the two parts of an interview; from the standpoint of the reporter, and the shooting of the interview by the camera operator.

Interviewing is the part of ENG that camera operators find the most boring. There are already too many "talking heads" on television news programs, but when they have something interesting and significant to say, they are an important part of the daily news. Use them to tell the story, when they are the authority or when they are closer than you to the story. Just be sure that what they have to say is pertinent or important.

Camera location in relation to the subject is very important and there are several commonly used shots and angles. The most common angle used is over the shoulder of the reporter. (See Fig. 3-1 Interview Camera Angles). From this angle, you can affect three widely acceptable camera shots. With a wide field of view (the long shot), the reporter and subject are shown together.

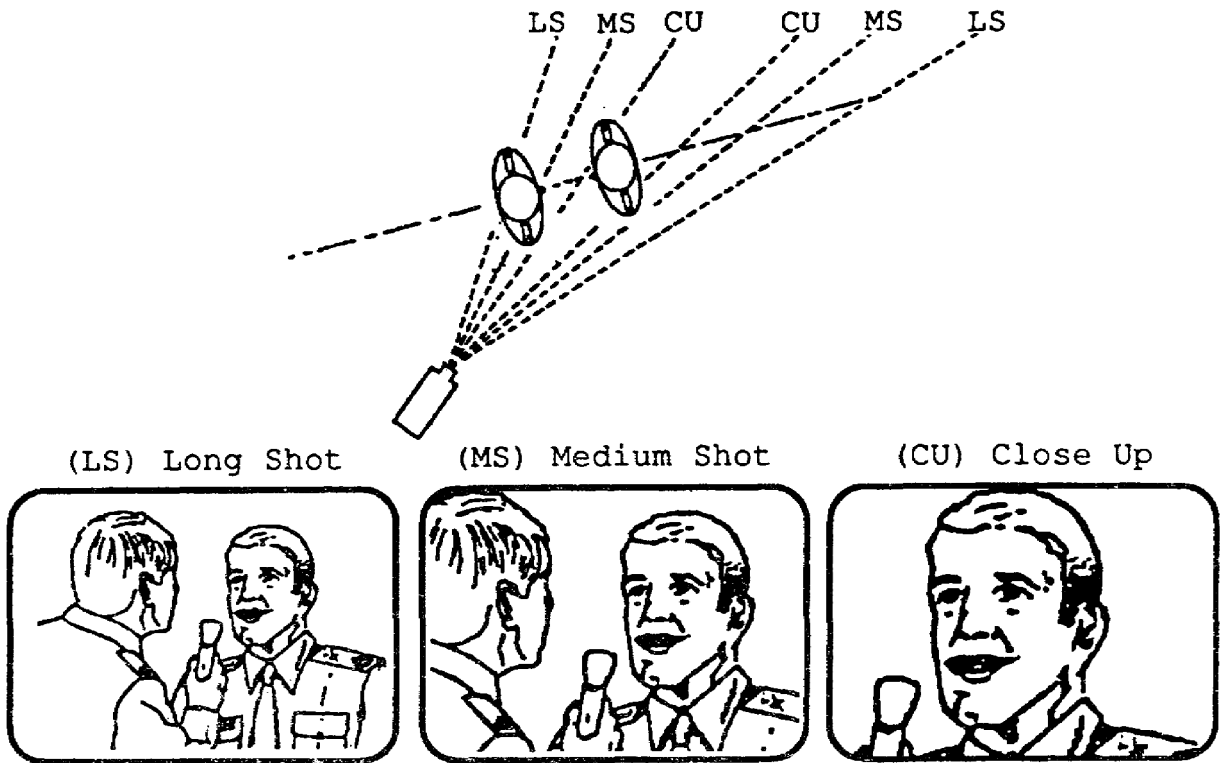

FIGURE 3-1. INTERVIEW CAMERA ANGLES

This shot shows the viewers that what they are looking at is an interview. A medium shot will still have a portion of the reporter in the picture while allowing the audience to get a closer view of the subject. It will still give the viewer a sense of the closeness of the subject to the reporter. And of course, the tight shot doesn't show the reporter at all and gives the viewer a close up view of the subject.

During an interview, the person being interviewed will usually be tense and nervous. After all, he is for the most part, doing something completely foreign to him. This can be overcome by an experienced reporter, and indeed, it's his job. Let the interviewee know that he is to give his answers directly to you, to look at YOU when he answers YOU. It's important that you look back at him when he is talking to you. This will make it more like a natural conversation to him. Put him at ease. He will be depending on you as a security blanket and confidant.

The over-the-shoulder angle establishes a line of action. Whichever shoulder you shoot over, all shots should be on that side of the reporter and subject (Remember the 180 rule?). And of course, remember all the little tidbits of information you learned about plants growing out of people's heads and so forth. You can make the background fit the interview. You can separate the background with light and darkness. You can lose the background with depth of field.

Another thing you should know when it comes to the interview is the four-point lighting system, even though most portable lighting kits have only 3 instruments (See Fig. 4-2, Four-Point Lighting System).

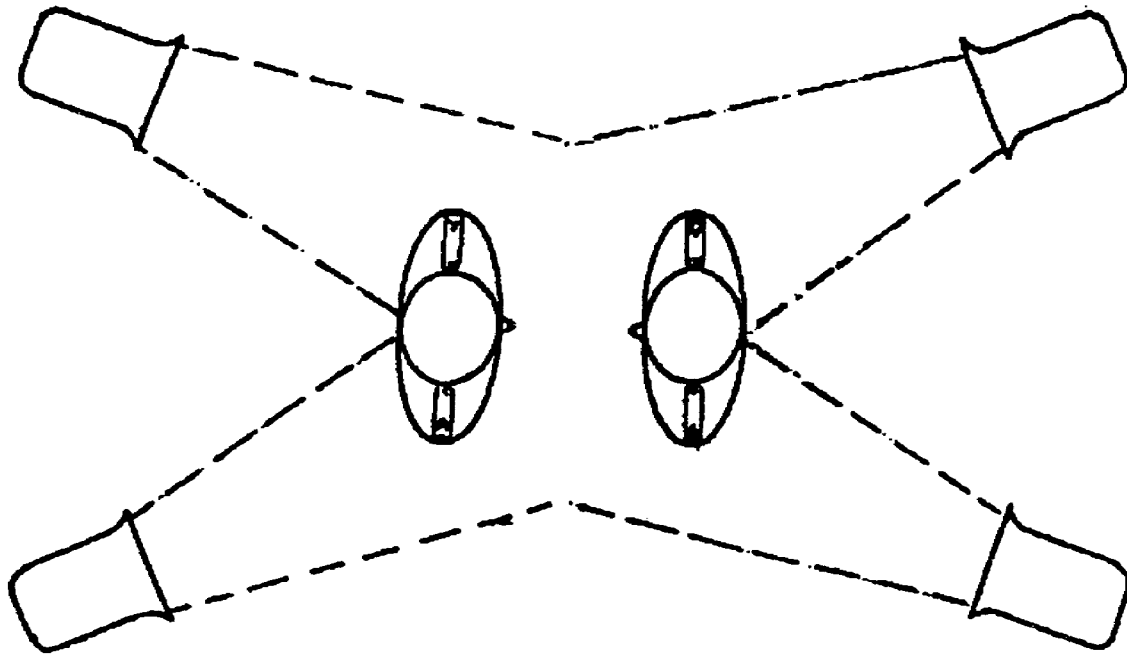

FIGURE 3-2. FOUR-POINT LIGHTING SYSTEM

In the four-point lighting system, the key light for one subject is behind the other subject and works as a back light when the beam is spread just a bit. With the addition of the fill light on the same side, you then have a combination of the three-point lighting system and the modified three-point lighting system. The key and fill lights for one subject work the same as the two back lights of the modified three-point system for the other subject. And of course the other subject has a key light and a fill light in addition to the two back lights.

## EDITING

After all the functions you've performed in announcing, writing, scripting and interviewing, you have still more. It's like all the parts of an automobile. They've been manufactured, but they're still just parts. They must be assembled to make a car. The same holds true for your TV news insert. You now have all the parts, but you must assemble them. That job is called editing, and just as in the assembly of the car, you still have important work yet to do. Depending on local SOP, there will probably be additional elements to add to what you've already shot in the field, such as color bars, countdown leader, start flash, etc. While you edit the PRIMARY and SECONDARY footage you shot in the field to your slave tape, you'll keep a close eye on audio and video levels. Keep the quality level of performance high as you perform these routine and sometimes boring



tasks. Make sure all your edits are clean and avoid jump cuts. (Lesson Four, Subcourse DI0350,)

A few years ago, the Ford Motor Company informed the public in its commercials of how to spot poor automobile assembly, what to look for in the showroom. The gaps at places where parts joined. What a seam between door and fender should look like. Evidently they felt that they did a better job than their competition in putting together equally good parts. Proper assembly is important. It's so important, that this subcourse devotes an entire lesson to it even though there was an introductory lesson to it in Subcourse DI0350. Therefore, we're just going to emphasize the importance of it here, and refer you to Lesson Four. Go forth and learn more about videotape editing.

PRACTICE EXERCISE

LESSON 3

SUBCOURSE NO. DI 0351

PREPARE/PERFORM TV NEWS INSERTS

INSTRUCTIONS:

Review the material in this lesson. Answer the questions below by circling "T" or "F" next to each question. Compare your answers with the answer key on the next page.

- T F 1. TV news inserts make up a very small portion of the electronic journalism business.
- T F 2. The basics of any news story are the who, what, when, where, why and how.
- T F 3. How you word your questions will have a lot to do with how an interviewee will perform.
- T F 4. The news feature is fast breaking and allows no time for planning.
- T F 5. The six C's of broadcast writing are: clear, concise, courteous, complete, current and correct.
- T F 6. Material in parentheses is information not normally meant to be read aloud.
- T F 7. The spot news event and the news feature are the two types of news reports.
- T F 8. Department of Defense spots may only be aired once.
- T F 9. You should include as many facts in the opening of a story as you can.
- T F 10. You should triple space lines at places in the copy where video changes occur.
- T F 11. You should never interrupt an interviewee in the middle of an answer.
- T F 12. The lead of a story should grab the audience's attention.

ANSWER KEY

PRACTICE EXERCISE

LESSON 3

SUBCOURSE NO. DI 0351

PREPARE/PERFORM TV NEWS INSERTS

1. FALSE (Page 36)
2. TRUE (Page 37)
3. TRUE (Page 66)
4. FALSE (Page 59-60)
5. FALSE (Page 37)
6. TRUE (Page 43)
7. TRUE (Page 59)
8. FALSE (Page 51)
9. FALSE (Page 38)
10. TRUE (Page 49)
11. FALSE (Page 66)
12. TRUE (Page 51)

## LESSON FOUR

### EDIT VIDEOTAPE

46R Soldier's Manual Task: 214-177-1318

#### OVERVIEW

##### LESSON DESCRIPTION:

This lesson will provide you an overview of editing video-tape.

##### TERMINAL LEARNING OBJECTIVE:

ACTION: Describe procedures necessary to properly edit videotape.

CONDITION: You are given the material presented in this lesson.

STANDARD: Perform all the duties described in this lesson.

REFERENCES: The material contained in this lesson was derived from the following publications:

STP 46-46R14-SM-TG Soldier's Manual &  
Trainer's Guide, Broadcast Journalist,  
MOS 46R Skill Levels 1/2/3/4, August 1988.  
Defense Information School Radio and  
Television Handbook, May 1982.

## **EDIT VIDEOTAPE**

### **INTRODUCTION**

The most useful or important thing about videotape is the fact that you can edit it. Editing can range from simple cut-only edits to electronic edits that go through switchers and effects banks to create dazzling special effects. The kind of system available to you will determine the degree of complexity and level of accuracy in your editing. All 3/4 inch video cassettes require an inserted red pin to permit editing on them. Whenever your system won't edit, check that first.

### **MECHANICAL EDITING**

In the early days of videotape recording, the only way to edit videotape was to physically cut the tape and splice it back together the way film is edited today. This is extremely difficult because unlike film, which is a physical or chemical process from start to finish, videotape is all electronic. You can't actually see where a picture starts or stops on the tape, and you can't just cut it anywhere like you can audiotape. It has to be spliced between invisible electronic video frames to prevent the picture from tearing and breaking up during playback. There is a special fluid you can apply to the control track to make the electronic pulses visible in order to splice between them, but they are visible only under a microscope. To make matters worse, there is a separation between the video heads and the audio heads making the audio at a different place on the tape than the video. Also, the video is diagonal due to the helical scan process. The complicated process of cutting and splicing videotape is all but a forgotten art, and is now used only in cases of extreme emergency. Today, videotape editing is done electronically.

### **MANUALLY CONTROLLED ELECTRONIC EDITING**

The problems you face with mechanical editing, trying to locate the exact edit point and trying to cut precisely, are no longer problems with electronic editing. Electronic editing is a transfer process where a playback machine transfers the recorded segments of program material to an edit/record machine. In other words, it's simply a dubbing process where the recording machine copies the material from the playback machine. With most videocassette editing systems, there are playback machines, record machines, TV monitors and edit controls (See Fig. 4-1 Videotape Editing System). The edit controls allow you to find accurate beginning and ending --"in and out" --points for your edits. The TV monitors allow you to

view the video being played back and the video being recorded. The editing controls shuttle the tape back and forth, allowing you to do the actual edits.

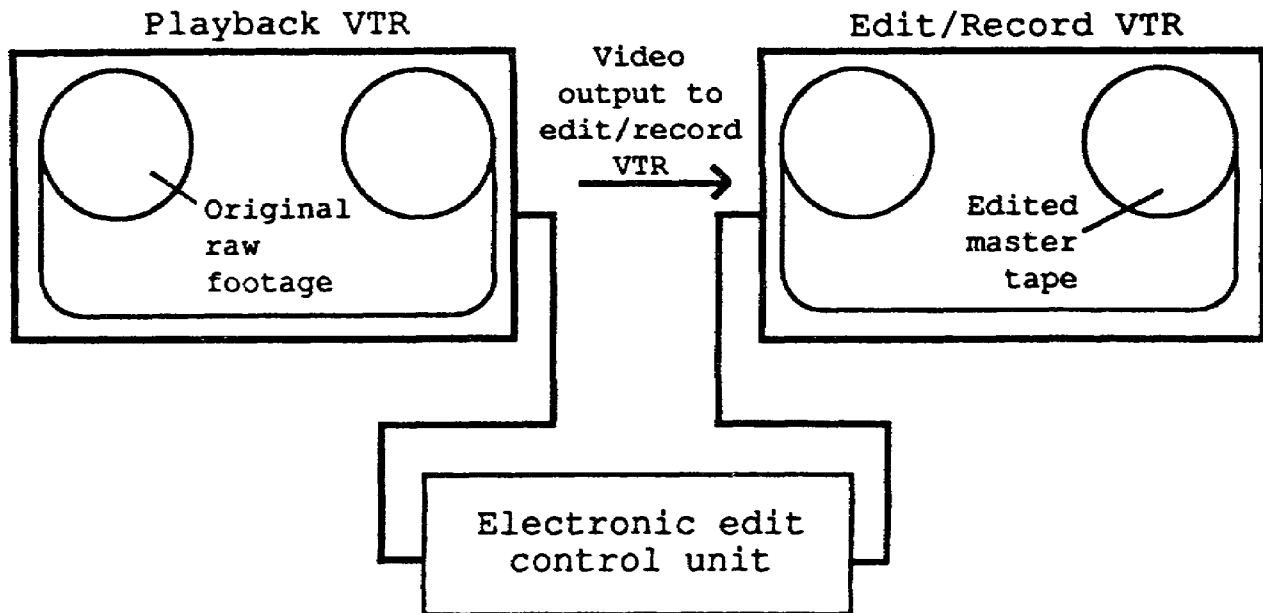

FIGURE 4-1. VIDEOTAPE EDITING SYSTEM

It is already obvious that videotape editing differs from audiotape editing. So far we have spoken of one manner only. The second way it differs is due to the fact that videotape takes a second or two to get to the proper speed and stabilize. That means that the tape must be traveling the correct speed with all the electronics stable when the edits are made. This can be a little tricky in the manually controlled electronic editing process. It's called "editing on the fly."

The process is usually done in six steps. They are as follows:

1. Determine the "in" point on the record/edit machine. It would be a good idea to play the scene over a few times to be able to hit the exact same point with regularity. This will be the point where you want the next scene to begin.
2. Find the "in" point on the playback machine. That's the point where the new material begins, the material you want to transfer to the tape you're creating.

3. Rewind both machines exactly the same number of seconds and frames. This is called the preroll, and it is used to give both machines enough time to get up to speed and stabilize before the edit is actually made. In manually controlled editing, it should be about ten seconds. Just make sure that both machines are rewound EXACTLY the same amount.

4. Next, start both machines in the play mode at the same instant and watch the record/edit machine monitor. When it gets to the precise point where you want the edit to begin, push the record button. This will change the machine from playback to record while everything is rolling at the proper speed and all the electronic circuitry is stabilized. You are now making the edit.

5. Let the edit (both machines) run past the point where you want the next edit to begin and then stop them. This is called a video pad. The purpose of the pad is to allow you the room to begin the next edit without having to be so precise on the in point.

6. Then, of course, recue the record/edit machine and check your edit. Make sure it's clean, without video break-up. If there are more edits to be made, start over with step 1.

It should be evident now that precision and accuracy are of utmost importance in this editing process. If either tape machine is the slightest bit off, the edit will be too early or too late. Too early means that you have recorded over something you wanted in the previous scene, and too late means you have gone beyond the desired point to begin the edit.

### **Assemble Edits**

All electronic editors permit you to edit in two modes. They are "assemble" and "insert." There are a number of facts about assemble editing that are not true about insert editing. They are:

1. The assemble mode edits everything on the tape to include the control track (See Fig. 4-2, Assemble and Insert Editing).
2. There is no preconditioning of the record/edit tape necessary.
3. Since the control track is laid with each edit, there is the possibility of a variance in the spacing of electronic pulses that will cause a tearing of the picture at that point (See Fig. 4-2 Assemble and Insert Editing).

4. Following each edit, there will be a loss of control track causing a "dirty edit." This makes it absolutely necessary to leave a video pad at the end of the edited segment.

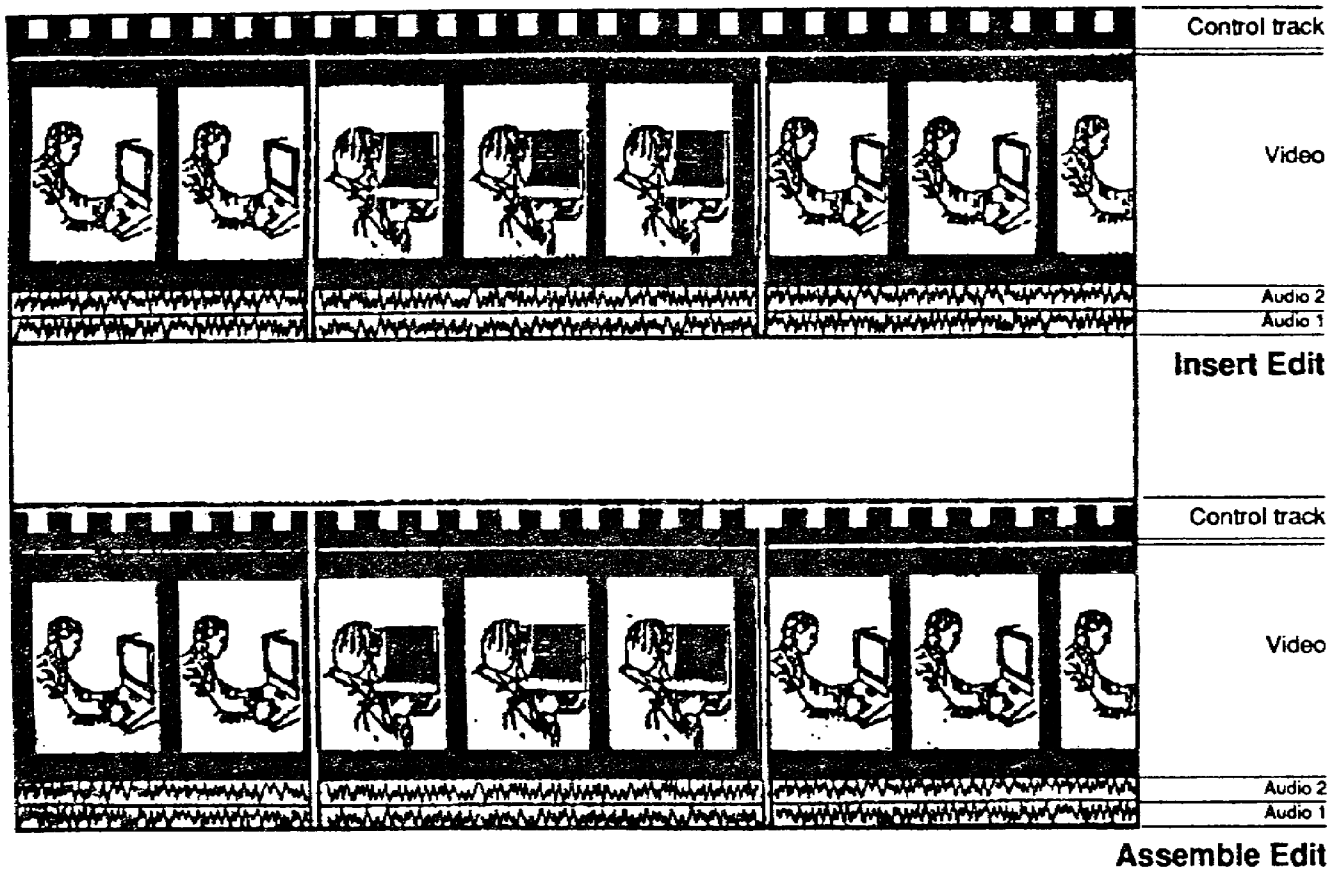

FIGURE 4-2. ASSEMBLE AND INSERT EDITING

### Insert Edits

The initial purpose of insert edits was to allow the addition of audio and video to programs that already existed. Everyday you see examples of such additions. The movies have done it since their beginning. For example, you may see someone looking into a box, then see what they see inside the box, then see them again for their reaction. Of course, the shot showing you what is in the box was shot separately from the other, and edited in later. To do this in videotape with the electronic editor, you need to select the in and out points in the insert mode. You must program the out point because otherwise the tape would continue to edit beyond where you want it to stop.

Insert editing uses control track that already exists and allows you to edit the video track, the audio one track, the audio two track or any combination of the three. Since no new electronic pulses are being laid on the tape, there isn't any danger of variance in spacing of the pulses that could cause tearing of the picture. It is a much more stable edit and most experienced editors prefer this method. The disadvantage though, is that you must first lay control track for the length of tape you intend



to use. A one-hour tape, for example, will require you to record an hour of control track. This is called crystal black and you must record it from another tape, studio output or a black burst generator. Of course, to record control track on your tape, you will have to be in the assemble mode. Your editing will then be done normally, but in the insert mode.

\* \* \* \* OPERATOR WARNING \* \* \* \*

After laying the control track in the assemble mode, be sure to change the edit control unit to insert mode. Once you begin to make your first video or audio edit, if you haven't changed out of the assemble mode, the end of the edit will be dirty and there is no way to correct it without re-laying the control track for the entire length of the tape.

Of course, if you think ahead, you'll have a supply of prerecorded crystal black tapes on hand so that emergency editing jobs or fast-breaking stories can be insert edited on a moment's notice.

### **PROGRAMMED ELECTRONIC EDITING**

There are several edit programmers or edit control devices available for both quadraplex and helical machines. They allow you to predetermine the exact points where you want the edits to begin and end.

Although the edit programmers differ slightly, the basic process works like this:

- o Find the in point on the record/edit machine by just cueing the tape to the exact spot where you want the edit to begin. There will be some sort of "edit in" button for you to set the point into the machine's memory. Do the same for the "edit-out" point.
- o Do the same thing on the playback machine to locate and cue the point where you want the new edit material to begin.
- o Most program edit systems will automatically preroll both machines. You can accomplish this now by setting some "automatic edit" function.

- o At this point, you may preview the proposed edit without actually accomplishing it. The record/edit machine will not actually make the edit on the tape, but will display it on the monitor without altering the edit in and edit out points. If there is something about the edit you wish to change, you can do it at this time. If not, you can simply execute the edit by either pressing the "auto edit" or "recue" and then "auto edit."
- o The "auto edit" may be called different things in different systems. It will most likely be "auto edit" or "edit record" or something that means the same. Whatever it's called in your system, it will start both machines simultaneously, lock them into synchronization, and make the edit precisely at the preprogrammed edit points.
- o Subsequent edits will be accomplished by repeating the process. Of course, you will want to review the entire tape after you have edited it to see if all the edits are clean.

PRACTICE EXERCISE

LESSON 4

SUBCOURSE NO. DI 0351

EDIT VIDEOTAPE

INSTRUCTIONS:

Review the material in this lesson. Answer the questions below by circling "T" or "F" next to each question. Compare your answers with the answer key on the next page.

- T F 1. The process of cutting and splicing videotape is the perfected new method of videotape editing.
- T F 2. Videotape takes a few seconds to get up to speed and stabilize.
- T F 3. Assemble edits edit everything on the tape.
- T F 4. Insert edits edit everything on the tape.
- T F 5. Many programmed electronic editing systems allow you to preview an edit before actually making it.
- T F 6. Insert edits always leave a dirty edit following the edit out point.
- T F 7. Preroll for manually controlled electronic editing is usually five seconds.
- T F 8. Electronic editing is merely a dubbing process.

ANSWER KEY  
PRACTICE EXERCISE  
LESSON 4  
EDIT VIDEOTAPE  
SUBCOURSE NO. DI 0351

1. FALSE (Page 76)
2. TRUE (Page 77)
3. TRUE (Page 78)
4. FALSE (Page 78)
5. TRUE (Page 81)
6. FALSE (Page 79)
7. FALSE (Page 78)
8. TRUE (Page 76)

## LESSON FIVE

### PERFORM AS ENG TEAM CHIEF

46R Soldier's Manual Task: 214-177-2301

#### OVERVIEW

#### LESSON DESCRIPTION:

This lesson will provide you an overview of performing as an ENG team chief.

#### TERMINAL LEARNING OBJECTIVE:

**ACTION:** Describe procedures necessary to properly perform as an ENG team chief.

**CONDITION:** You are given the material presented in this lesson.

**STANDARDS:** Perform all the duties described in this lesson.

**REFERENCES:** The material contained in this lesson was derived from the following publications:

STP 46-46R14-SM-TG Soldier's Manual &  
Trainer's Guide, Broadcast Journalist,  
MOS 46R Skill Levels 1/2/3/4, August 1988.  
Defense Information School Radio and  
Television Handbook, May 1982.

## **PERFORM AS ENG TEAM CHIEF**

### **INTRODUCTION**

The responsibilities of an ENG team chief can be stated very simply.... everything that has anything at all to do with the gathering of news electronically, is in one way or another, the responsibility of the ENG team chief. In some cases, there will be only one person to accomplish everything. In other cases, the ENG team chief will have little to do other than supervise and be responsible. In all cases, the ENG team chief is responsible for the final product: its technical quality, its thoroughness, its aesthetic quality and its ethics. A good ENG team chief must be prepared to supervise or accomplish all ENG tasks in all situations.

### **SELECTING EQUIPMENT AND PERSONNEL**

For the most part, there is little difference in civilian and military electronic news gathering. One difference that will become most obvious to you in the everyday performance of ENG team chief functions will be in equipment selection. In a civilian station, the news department has a lot to say about the equipment purchased by the station. In the military, however, your equipment has been selected by the proponent, within guidelines-established by the military procurement system. The equipment selection was made with an eye toward your mission and you should already have everything you'll need to do the job. You might say that the equipment has already been selected for you, leaving you only the choice of how much of the equipment you'll need to take to the site.

A big part of your responsibility as team chief will be to be sure that all the equipment is on hand, serviceable, packed and ready to go. Batteries need to be charged and you'll need a sufficient number of tapes with red pins. You must have the proper lighting equipment with electrical cords, stands, barn doors, spare bulbs, insulated gloves, screens and reflectors. The camera, recorder, tripod and connector cables will have to be ready. Don't forget microphones and cables. In short, you'll need to know what equipment will be needed for the project and take the needed steps to get it on location.

The ENG team chief must also select the team members for each production from those persons available. Other duties, leaves, passes, temporary duty assignments, illnesses and personal abilities or limitations are all factors you must consider.

Your most valuable asset will be checklists. Experience will make things routine, but you should never rely strictly on your memory. There is a lot to think about in the business of ENG and your mind will always be occupied with many other things. A checklist for the equipment required for each type of production you'll be called upon to do, will be not only a timesaver, but the insurance that will prevent a disaster sooner or later.

## **CONDUCTING SITE SURVEYS**

A very small portion of what you do will be spot news stories. A large part will be coverage of planned events. That will allow you to conduct site surveys. Before you can produce successfully at a remote location, you must conduct a site survey.

There are many things you'll need to know about the ENG location, and the time to find them out is in the planning stage. Where should the camera be positioned? How much light is available? Where can we park? How far must we carry the equipment from the vehicle? Will there be enough electrical power for the lights and other equipment? Will there be outside noise to worry about? What about problems with mixing of color temperature of light? (More about this in "Determining Lighting Requirements"). You'll need the answers to these and more questions.

Site surveys have three main purposes. They are: to determine the location for the production, to determine where all the production equipment and personnel will be positioned, and to determine if all the production's needs and requirements can be handled at the site. Very often, the first question, "Where is a suitable location?" is answered by the event itself. A change of command ceremony, for example, will take place on the parade field or in the theater in case of inclement weather, and you won't have much to say about the location. On the other hand, something like a training exercise will give you some options as to what particular segment you'll cover and therefore, some option as to location.

If you're covering something outdoors, make your site survey at the same time of day you intend to cover the event. That way, the daylight will probably be the same, if the weather is anywhere near the same. At least, you'll be able to position the camera or cameras with the back to the sun. It would do little good to conduct a site survey at 8 o'clock in the morning with the sun in the east if the event is going to take place at 4 in the afternoon when the sun will be in the west. When you know exactly where the sun will be, you'll see the length and position of shadows, contrast between light and dark areas and anything else time related.

Although it may seem that indoor events would not make any difference as to what time of day you need to conduct the survey, it's not always the case. Traffic patterns might be different and affect your ability to get somewhere in a certain length of time, or the availability of parking might change, or even a change in the pedestrian traffic at the location could give you problems. There could even be a large difference in the drain on electrical power from one time of day to another.

Finally, take nothing for granted. Do the electrical outlets you intend to use actually work? Does that window you want to run a cable through really open? Is that elevator or escalator going to be working when you will need it, or will it be turned off? It's certainly better to oversurvey the site than to miss one important point that will lead to a disaster later.

While every remote production site will differ at least slightly, there are still some common points that must be considered by the ENG team chief.

### **Local Contacts and Clearances**

You should always have a local contact who can provide access, information, and help with various details. It might be someone connected with the site, or someone connected with the event. If it's someone connected with the event, you may have to have another contact who is connected with the site or facility. Get their names and phone numbers, and those of any assistants who might also be helpful. When possible, you may also want to establish contact with electricians, plumbers and maintenance people.

**Access.** Establish where you'll need access to the site, when you'll arrive, how you'll get your equipment from your vehicle to the working area, and what help, if any, you'll need. If you're going to be arriving at odd hours, make sure someone will be on hand to grant you access.

**Permits.** If your event is in the civilian world, remember they require permits for everything. You may need a police permit to park vehicles on the street. You may need special permission to block traffic. You may need some help with crowd control so you have an unobstructed view of the event. Of course, you will want to prevent any danger to your equipment from a crowd. Whatever you need in the way of permits should be obtained well in advance of the scheduled event.



**Permission.** There are many places where you'll need special permission to gain access. There may be security precautions. Maybe you'll be covering something that takes place in a camera restricted area. You'll need, not only an escort, but something in writing to show that you have the permission to enter and videotape in the area. In the military, a memorandum for record will usually suffice. If you're going to be escorted by the public affairs officer or his representative, it might not be a bad idea to be sure they have the permission they need to get you in. Of course, that is something that must be handled tactfully. No one likes to have you hint that he might not know what he's doing. Usually a question like, "Does this building require any special permission to bring a camera in?" will do the trick.

**Parking.** You'll need to arrange for parking for your vehicle as well as any privately owned cars of your crew. Sometimes you won't have much say in the matter, but try whenever possible to have your production vehicle as close to the shoot site as you can. You never know how many trips you'll have to make back and forth, or how urgent one of them might be. Don't forget that you need to have unrestricted movement back and forth to your vehicle as well.

### **Cameras**

Positioning of the camera(s) is an extremely important decision that you must make during the site survey. Will you be required to move a camera at some point during the event? Be aware of reflecting surfaces and the possibility of the camera capturing its own reflection. If there is more than one camera, keep them out of each other's shots, unless that's the effect you're looking for. Don't forget screen direction and the 180 rule.

Try to anticipate things that could happen during the event to affect your camera shots, such as an audience rising to its feet and blocking the camera's view. Think about people moving around and make sure tripod legs are not going to get kicked or tripped over.

### **Audio**

Even in the studio, under very controlled conditions, the production of high-quality audio is difficult. When you throw in all the acoustical problems and unplanned noise you experience at a remote location, the problems magnify.

Some of the basic things you'll need to know at site survey time are:

- o What sound sources (including people) must have microphone?
- o Will the microphones appear in camera shots? Is that acceptable?
- o What potential audio problems are there? (external noises like air conditioners running, etc.)
- o Are there any special arrangements to be made such as pool audio or tying into a public address system?

With the answers to these questions, you'll be able to decide what microphones you'll use to get the high-quality audio you want and need. All your decisions will be made while considering the equipment available. You'll consider the pickup patterns available. Sometimes you may even have to compromise somewhat because of limited availability of equipment. Experience will help you avoid, or at least minimize such compromises, but site surveying will help you keep the quality of the audio within acceptable standards.

**Talent.** Announcers, play-by-play sportscasters and commentators can usually get by with lavalier or hand-held microphones. If you have a headset microphone, it will allow hands-free operation and maintain a constant announcer-to-microphone distance. You must consider any movement flexibility required. Maybe, you'll want to use a wireless microphone. Will there be any external interference? Of course, if you use normal cables, they should be run around any high-traffic areas and away from power lines.

**Natural sound.** The natural sounds are necessary to make any event real and believable. You'll rely heavily on the camera microphone, but sometimes you may even have to place a microphone for optimum reception of natural sounds. Consider the pick-up patterns you'll need. Crowds, for example, will best be captured with an omnidirectional pattern. Your camera microphone is a shotgun or supercardioid pick-up pattern.

### **Power**

Calculate the production's total power requirements, and be sure the power you need is available. Besides noting the voltage and amperage, make sure the wiring configuration is compatible with your equipment.

You have batteries for your equipment and usually that's the simplest way to go, but remember, batteries limit the amount of operating time. Also, after you have used up your batteries, you can't use them again until after recharging.

What if some fast breaking news story requires you on the way back to the station? If you just used all your batteries, you can do nothing about it. Always use available AC power at the site when you can. Save your batteries for the emergency that will always pop up when you least expect it.

Check all outlets in advance. Never assume that they work. Know where the breaker box is located. Try to spread your power requirements out as much as possible to avoid blowing a fuse or throwing a breaker in the first place.

**Cables.** Plan the power cable runs to cameras, recorders, lighting instruments and any other production equipment. Don't use extension cords intended for home use. They are too thin a gauge wire for your requirements. Make sure your cables are the heavy-duty, insulated electrical cable for professional use that provide the durability, safety and power load for a remote situation. Plan not only on the number you'll need, but the length as well. When planning the power cable runs, remember that they should not be run where they can interfere with audio cable signals. Don't forget to keep them out of the camera shots.

### **Communications**

There are two types of communications you must consider when surveying the site. Are there telephones available to call back to the station if necessary? What kind of communicating are you going to have to do during the event between crew members? Will you need PLs? Can you do what communicating you need by sign language? Never leave yourself unable to communicate or restricted in your ability to communicate with your crew or your on-site contacts, if you can possibly avoid it.

### **Security**

Will you require any special security arrangements? How about for your equipment? Be sure your equipment is secured against both theft and damage. People have no concept of the cost of television equipment. They can't imagine a camera costing more than an automobile and their treatment of them reflects it.

The remote location site may have security that will require you to have credentials and passes. During the site survey is a perfect time to arrange for them. You'll have to specify how many people you'll need passes for, to include staff, technical crew and talent.

## **Food and Lodging**

Your local contact will be a great help in providing food and lodging for your crew, but it's up to you to make sure that it's taken care of. Your job, no matter what rank, is that of a first sergeant, taking care of the troops. It's a good idea to keep everyone together for meals that are during the production, such as breaking for lunch. Then you won't have to wonder if everyone is going to make it back for the afternoon session. When covering something like a field exercise, you'll probably eat with the troops anyway and your crew will then be in close contact with you for the entire break.

Even if you don't have to provide a full meal, some sort of coffee and doughnuts (in cold weather) or cold drink and a snack (in hot weather) will be greatly appreciated. The lift in morale will be well worth the effort on your part. Of course, if you need to be on location overnight, it's up to you to arrange billeting for the crew.

## **Transportation**

You are responsible for transportation, not only to the site, but to and from the lodging for the duration of the production. That can be something very simple, or a major logistical operation.

## **Construction**

Will there be any special construction required? Scaffolds to serve as camera platforms, or lighting or announcer platforms? If so, find out during the site survey and have everything done prior to the event.

## **Graphics**

If the production is going to require any graphics or character generation, you should plan it at this time. Knowing ahead of time will allow you to make available to yourself the graphical equipment you'll need. After the on-site production, you may not have time to get the graphics together and shot in time to meet your deadline. At the time of the site survey, you will probably be able to anticipate all of your graphic needs.

## **PRODUCTION MEETING**

Once the site survey has been conducted, the final preparation point is to have a production meeting. Even if there are only two people who are going to accomplish all the tasks, it is necessary for those two to meet

and discuss all facets of the production. Be sure that everyone knows what his job is and that all jobs are covered by someone.

You have tried to think of everything that needs to be addressed. You've asked yourself questions about everything that is likely to happen. Now ask questions concerning some things that are even unlikely. Make some contingency plans. Just like defensive driving, expect the unexpected. If you have already asked yourself what you would do if a certain thing were to occur, and answered the question, you will be well prepared to handle the situation if it does occur. Of course, if on the other hand, you haven't even thought about that same possibility, the chances are pretty good that it will cause you a lot of problems.

## **DETERMINING LIGHTING REQUIREMENTS**

### **Outdoors**

During the daytime, there will usually be enough light outdoors to satisfy the technical requirements of the camera. That doesn't mean that you will have nothing to do about the lighting. There are a lot of different circumstances that can require additional lighting outdoors. It's your concern, as ENG team chief, to ensure, not only sufficient lighting, but proper lighting for the production. Just because you're going to be shooting outdoors, don't neglect to carry with you and plan the use of lighting instruments, sun guns, reflectors, stands, cables, screens, scrims, barn doors, spare bulbs, fuses and any other piece of equipment necessary. Remember color temperature when augmenting lighting outdoors.

### **Indoors**

All of the equipment you MIGHT need outdoors to help ensure proper lighting, you WILL need indoors. The event you're covering will most likely be lighted for human eyes and not for television. As you know, the camera requires a certain amount of light to operate, and it's your job to supply that light. This can be a serious problem in a lot of situations. The person in charge of the event may have reservations about television lights and the chance that they could interfere with the event itself. You have to know how the lighting could cause heat, glare and distractions to persons involved in the event, and reassure those responsible.

Consider having a properly lighted area for interviews off to the side somewhere. Think about lighting a portion of the event if you can't light everything that's taking place. In lighting an event indoors, also

consider your ability or inability to control all the light on the scene. If there is light of another color temperature that you can't eliminate, you must white balance for the mixture that you'll be shooting. If you eliminate some other light, be sure to repeat that step when the event actually occurs.

Much of the time, you will have to have a lot of tricks up your sleeve in cases where the event is taking place in a large area indoors. More and more, portable television cameras are requiring less light to operate. Know what your camera needs and be sure you operate within your system's limits, and be sure that both the technical and the aesthetic requirements of lighting are satisfied.

### **PRETESTING EQUIPMENT**

Just because everything was working at the last event, doesn't mean that it's still going to perform up to standards for you. Of course, if you weren't the last one to have the equipment out, you will want to know that everything is still working before you depend on it. It has been transported since its last use and that in itself could be enough to cause something to malfunction.

There is no substitute for proper care of equipment and in spite of the best care, things still go wrong. The time to find out if something isn't working properly is before you need it. As you are undoubtedly becoming aware, every piece of your equipment plays a vital role in the accomplishment of your mission. One piece not working properly can ruin your whole production. Be aware of Murphy's Law (anything that can go wrong will go wrong), and take away as many possibilities of failure as you can.

### **COORDINATING TRANSPORTATION**

During your site survey, you found out exactly what transportation would be required. Knowing about it doesn't get it done. You have to follow up and be sure that you can get everyone and everything to the site. Don't depend on someone at a motor pool somewhere understanding the importance of your mission. They have worries of their own and somehow your getting the event covered doesn't rank too highly on their list of priorities. Have emergency back-up plans to cover the possibility of someone not keeping their promise.

## **ASSIGNING AND BRIEFING PERSONNEL**

Most of what you do as ENG team chief will touch on the responsibility of assigning and briefing personnel. Unless you are going to be doing absolutely everything yourself, and chances are, you're not, you will need to be certain that each member of the crew understands his responsibilities. To correctly assign personnel, you must know them. Know their strengths and weaknesses. Then it's a matter of using your resources properly. Assign personnel to the jobs they can best fill and keep them away from those tasks they're not qualified to perform. Above all, you must be sure they understand what is expected of them and what they need to do in order to accomplish it.

## **SUPERVISING ON-SITE SETUP**

Unlike studio productions, where certain necessary elements are in place and set up all the time, every remote situation must be set up from scratch. As soon as you arrive on the scene, you'll begin to work on getting things in the order of the plan you made during the site survey. Cameras will be unpacked and placed at planned locations and set up on tripods. You'll already have built any necessary platforms, stands or barriers. Once you've accomplished this, the operators will power up the cameras and recorders and go through their checklists.

Those responsible for audio will unpack equipment, run cables and place microphones (hand, lavalier, boom, shotgun, etc.) at the proper locations. Depending on how many microphones and the likelihood of confusion, you may want them labeled with the name of the person who will use them. At each audio position, you'll want to run an audio check, then make certain the instrument is secured in a manner to make sure it won't be mishandled or damaged before the production.

All necessary lighting instruments should be set up, tested, positioned and focused. Since this takes a little time and everything else depends on lights, you may want the lighting setup to begin a little earlier than other things so that everyone won't have to wait for lights. For elaborate situations, you may even want the people responsible for lighting to arrive before everyone else.

Once everything is in position and set up, you'll want to check it to be sure that it all works properly. The transporting is over for now and what still works, will probably continue to work. Within reason, try to keep spare parts such as extra light bulbs and so forth, close to where it might be used. If a bulb were to burn out, you wouldn't want to hold everything up while someone had to run out to the truck to get a spare, or

miss covering that much of the event. Of course, you can't keep two complete systems on hand in immediate reserve either.

A final briefing before the action begins is always a good idea. Everyone should have one last chance to ask questions and clarify his role. That way, the team will know what each member needs to do, and be sure all bases are covered.

### **SUPERVISING REHEARSALS AND SHOOTS**

If you have the opportunity, rehearse. The more you do anything, the better you'll be able to do it, and rehearsing the production will enable you to work out any difficulties as well as point out to you where they may pop up unexpectedly. An uncontrolled event such as fast-breaking spot news will certainly not allow for rehearsal, but if your crew has worked together in the past and rehearsed at every opportunity, they will be able to function as a tightly knit team in all situations. Even if an event seems routine to you, the entire team can benefit from rehearsal.

### **SUPERVISING ASSEMBLY OF THE FINAL PRODUCT**

As stated in chapter three, after all the functions you've performed in announcing, writing, scripting and interviewing, there is still more to do. As ENG team chief, the same holds true. After all the functions that have been performed in surveying, coordinating, setting up, shooting and everything else, there is still more.

There are still to be made. What TREATMENT WILL YOU GIVE THE COVERAGE IN FINAL EDITING? Will you use music? Will you try to make the coverage hard hitting or just matter-of-fact? These are decisions that you, the ENG team chief, must make. You can seek and rely on advice from your crew, but in the final analysis, you are responsible. When credit is given for a job well done, it should be shared among everyone who contributed, for they all had a hand in keeping the standards up and making the product excellent. When the standards are not up and the product is not excellent, there is only one person to blame. The person in charge.



PRACTICE EXERCISE

LESSON 5

SUBCOURSE NO. DI0351

PERFORM AS ENG TEAM CHIEF

INSTRUCTIONS:

Review the material in this lesson. Answer the questions below by circling "T" or "F" next to each question. Compare your answers with the answer key on the next page.

- T F 1. Since the military trains personnel in all facets of ENG, it doesn't matter which person is assigned to which position in the crew.
- T F 2. The camera microphone is the only acceptable way to capture natural or background sound.
- T F 3. A production meeting after a site survey is a good time to be certain that everyone understands what is expected of him.
- T F 4. Site surveys are to determine where all the production equipment and personnel will be positioned.
- T F 5. After all the functions have been performed in surveying, coordinating, setting up, and shooting, the ENG team chief has fulfilled all his duties.
- T F 6. If your equipment was working properly at the last production, and still functioning at the station, there is no reason to suspect it won't work well at the new location.
- T F 7. It is the responsibility of the ENG team chief to decide what equipment should be purchased for remote productions.
- T F 8. You should rehearse coverage of routine events.
- T F 9. The ENG team chief is responsible for getting the entire crew to and from the site of an event.
- T F 10. Camera positioning should not be determined until just before an event begins since plans often change and you want to avoid unnecessary extra movement of delicate equipment.

ANSWER KEY

PRACTICE EXERCISE

LESSON 5

SUBCOURSE NO. DI0351

PERFORM AS ENG TEAM CHIEF

1. FALSE (Page 95)
2. FALSE (Page 90)
3. TRUE (Page 93)
4. TRUE (Page 87)
5. FALSE (Page 96)
6. FALSE (Page 94)
7. FALSE (Page 86)
8. TRUE (Page 96)
9. TRUE (Page 92)
10. FALSE (Page 89)